

# DARAY®



## WAVELITE

**CEILING, WALL AND MOBILE  
INSTALLATION AND  
OPERATING MANUAL**

DAR.GAM.WAVELITE.2.0811

CE 0120



# DARAY®

<b>1. GENERAL DESCRIPTION</b>	<b>4</b>
<b>2. SPECIFICATION</b>	<b>5</b>
SERIAL NUMBERS AND LABELLING	5
<b>3. OPERATION</b>	<b>6</b>
<b>4. MAINTENANCE</b>	<b>8</b>
ADJUSTMENT OF LIGHT-HEAD TENSION	8
CLEANING AND DISINFECTING	9
ROUTINE MAINTENANCE	9
<b>5. ADJUSTMENT OF ARM TO PREVENT DRIFT</b>	<b>11</b>
<b>6. INSTALLATION</b>	<b>12</b>
Installation - Ceiling mount	12
Installation - Wall mount	18
Assembly - Mobile	20
Installation - Fit the jib-joint cover (all models)	22
Installation - Fitting the head (all models)	23
<b>7. FUSE REPLACEMENT</b>	<b>24</b>
<b>8. SPARE PARTS</b>	<b>24</b>
<b>RETURNS POLICY</b>	<b>25</b>
<b>WARRANTY</b>	<b>26</b>
<b>WARRANTY REGISTRATION</b>	<b>29</b>

Tel: 0844 375 9000 Fax: 0333 321 0973

email: [info@daray.com](mailto:info@daray.com) url: [www.daray.com](http://www.daray.com)

## 1. GENERAL DESCRIPTION

The DARAY Wavelite is a high-quality LED dental surgery light available as wall, ceiling and mobile versions. The Wavelite has variable intensity with an aesthetic, robust and efficient light-head.

The Wavelite is for use during general dental diagnosis, surgery and cosmetic dentistry.

Its 6,000K colour temperature ensures the natural colour of the dental cavity is not distorted.

Daray's BioProtect® anti-microbial coating is applied to the arm component surface, and all other surfaces are smooth to aid cleaning and sterilisation.

The light comprises 3 parts: a ceiling, wall or mobile mounting, a variable-intensity power-supply module containing a transformer to convert mains voltage to a safe low voltage to power the light, and a suspension arm with fitted light-head.

There are 2 versions of the power-supply module: one for use where the mains-electrical supply cables are 'chased' into a wall, and the other fitted with an IEC inlet so the mains may be supplied via a plug-in flex from a standard mains socket. The power-supply module is fastened underneath the wall-mount bracket for the wall mounted Wavelite and can be screwed to the wall to provide power for the device.

## 2. SPECIFICATION

Light output at 0.5m	0 - 20,000 lux @ 0.5m ± 5%
Colour temperature	6,000K natural white light
Power consumption	10W
LED module operating voltage	24V DC
Input voltage	100 ~ 240V 50/60Hz
Arm reach	1650 mm
Jib arm vertical movement	+15°/-45°
Quality approvals	 0120
Medical-device directive	93/42/EEC, EN60601-2-41

### Serial Numbers and Labelling

Each Wavelite is allocated a unique serial number located on the mounting arm, and is identified by a label also affixed to the arm.

The power-supply module carries its own identification and serial number.

### 3. OPERATION

If you have a ceiling mounted Wavelite, go straight to step 2.

1. Check that the mains indicator is illuminated on the power supply module.

If the mains indicator does not illuminate, check the mains supply and then the fuses in the module which are located on its right-hand side. For models powered via an IEC lead with a moulded mains plug, check the fuse in the mains plug.

2. Operate the light by passing your hand in front of the sensor.
  - Pass hand in front of the sensor (either direction) once to turn the light ON
  - Hold hand in front of the sensor to decrease intensity
  - Hold hand in front of the sensor and hold to increase intensity

When it reaches its maximum intensity a series of long beeps will sound. To dim the light, replace your hand under the light-head and the intensity will lower. Upon reaching its minimum intensity a series of short beeps will sound.

- Pass hand in front of the sensor in front once again to turn OFF

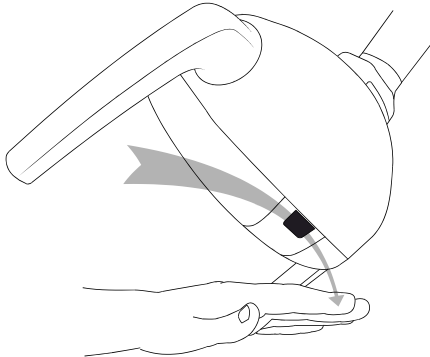

The infrared proximity sensing switch is located under the light-head. The control range is up to 100mm (4").

The controller remembers the last intensity setting when turned off and reverts back to this setting when turned on again.

Use the handles to steer the light-patch to where you want it; in the interests of cross-infection control, avoid touching any other part of the light.

The suspension arm swivels at the mounting and at the joint between the primary and jib arms. The jib arm allows the light-head to be moved up and down. The light-head itself can rotate 320° on the jib arm in both vertical and horizontal axes (note: mobile versions do not have a primary arm).

After use, switch off at the light-head switch and also, where applicable, at the power-supply module on the wall.

Warning: Mobile Models - transport the light using the handle on the up-stand.

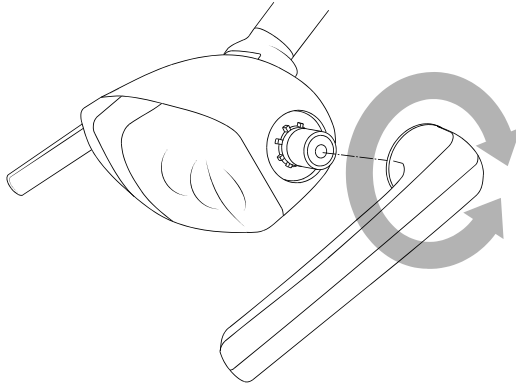

The WAVELITE handles can be removed and replaced in any one of eight different positions to suit the user's individual preference.

To remove the handle, hold the Wavelite head in one hand and pull off the handle with the other. Take care, as it may take some effort to remove the handle.

**Note: The handles are removable for autoclaving**

**Note: Do not force the light-head, this could damage the product.**

## 4. MAINTENANCE

### Adjustment of light-head tension

Remove the fascia by removing the two screw covers and removing the two screws.

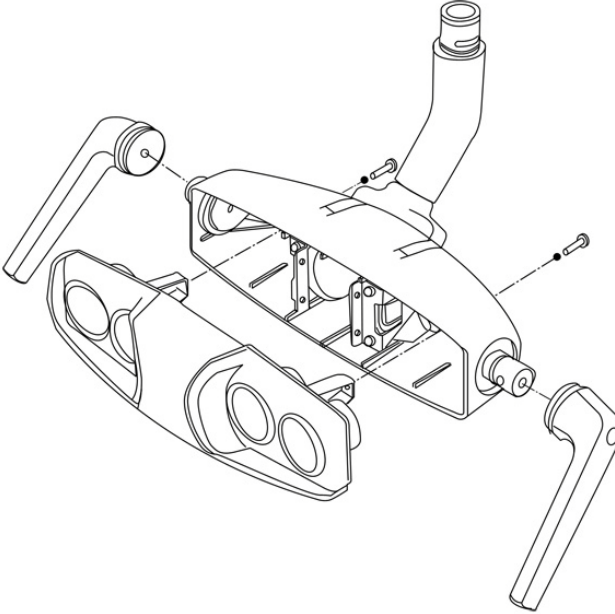

Adjust the screw inside the light-head to adjust the tension on the vertical adjustment.

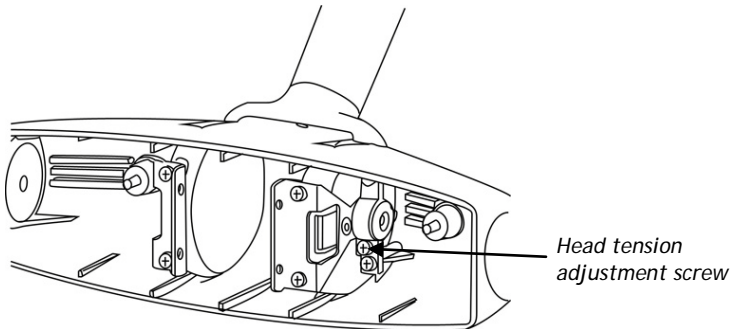

To increase the head tension, turn the screw clockwise.

To decrease the head tension, turn the screw anticlockwise.

## Cleaning and Disinfection

**WARNING: do not use strong chemical cleaning agents to sterilise the light. Do not use any abrasive materials to clean the light.**

**CAUTION the light is not waterproof, so do not use excessive cleaning fluid amounts.**

Suitably protect hands.

Wipe the light using clean tissue or soft towelling - pay special attention to the switch areas.

On all surfaces, apply a 1% solution of sodium hypochlorite using a soft cloth. Within 10 minutes, remove the chemical from all surfaces using a damp, soft cloth. The chemical will cause corrosion of metal parts, if it is not thoroughly removed.

Apply Isopropanol to the surfaces - this is an alcohol-based fluid which evaporates without leaving any residue and can be obtained as an impregnated-cloth applicator.

Do not autoclave the light-head steering handle, as it may damage the BioProtect® coating.

## Routine Maintenance

The Wavelite is designed and manufactured to stringent quality standards. Observing the following procedures will help to maintain the light's optimum performance.

### Light-head

Clean all exterior surfaces as required using the directions above.

### Arm

Operation	Suggested Intervals	Details
On wall-mounted units, lift the arm so its spigot is almost clear of the bush in the wall-mount plate and re-lubricate if required.	Six monthly	
On ceiling mount units, support the arm and remove the 3 screws retaining the fitting adaptor into the downtube. Lower the arm until the adaptor and key can be removed. Slide sleeve up and inspect for lubrication. Lubricate spigot and sleeve if required.	Six monthly	
Check tightness of all 5 fixing screws.	Annually	
Check balance of jib over the whole range of movement.	One month after installation and then annually	If tendency is to fall from fully up, insert key in capstan hole furthest away and with jib fully up move capstan by pulling key towards you. Repeat until no fall at top. Reverse capstan if rise at bottom of jib movement.

## Ceiling Mount

Operation	Suggested Intervals	Details
Inspect 6 socket screws for tightness and check that washers are fitted under head.	Six monthly	Tighten with appropriate hex wrench
Check that down post is rigidly mounted to the ceiling (do not exert undue force).	Annually	If any movement found - immediately advise your full service dealer

## Wall Mount

Operation	Suggested Intervals	Details
Check for security of fixing to wall	Annually	Investigate any looseness - ensure your building contractor is consulted if looseness found

## Mobile Mount

Operation	Suggested intervals	Details
Light-head		
Clean all exterior surfaces	As required	Disinfecting and cleaning directions - see above
Arm		
Check tightness of all fixing screws	Annually	
Check balance of jib over whole range	One month after installation and then annually	If unbalanced, follow the procedure, below. If tendency is to fall from fully up, insert key in capstan hole furthest away and with jib fully up move capstan by pulling key towards you. Repeat until no fall at top. Reverse capstan if rise at bottom of jib movement

## 5. ADJUSTMENT OF ARM BALANCE TO ELIMINATE DRIFT

Insert a small implement (e.g. hex wrench 2mm AF) into one of the holes and turn capstan in the direction of Arrow A until desired balance is obtained.

Note: To eliminate rise in the jib at the fully down position turn the capstan in the opposite direction to Arrow A.

To assist in making this adjustment, it may be necessary to remove the arm joint cover: Remove the 2 snap in plugs and the 2 screws, allowing the cover half mouldings to be separated and the moving cover to slide down the jib arm. This provides better access to the slot through which the capstan nut is adjusted.

**Note: When re-assembling, ensure that the moving cover is correctly positioned with the 'T' notation on the component at the 'Top'.**

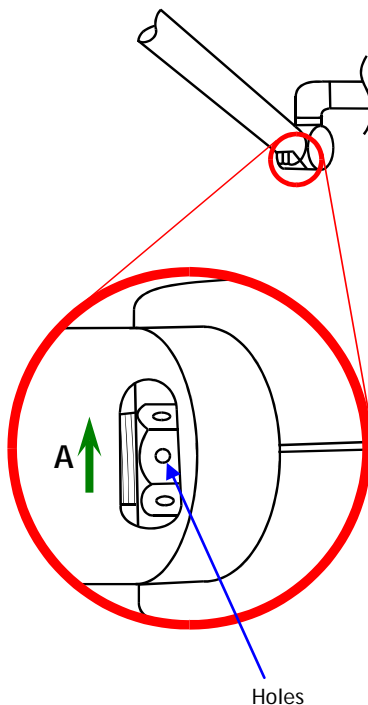

## 6. INSTALLATION

### Installation - Ceiling Mount

**CAUTION: this product must be earthed.**

Check you have the following items:

Ceiling-mount plate assembly and cover
Down-tube
Light-head on suspension arm
Down-tube bungs
Down-tube grub-screw
Down-tube spigot nylon washer
Grease sachet

Determine where to mount light from the positioning and ceiling-load forces diagrams, below:

**WARNING: please note that this information is provided for guidance only and that a qualified builder or structural engineer should be consulted if you have any doubt about the suitability of the proposed mounting position.**

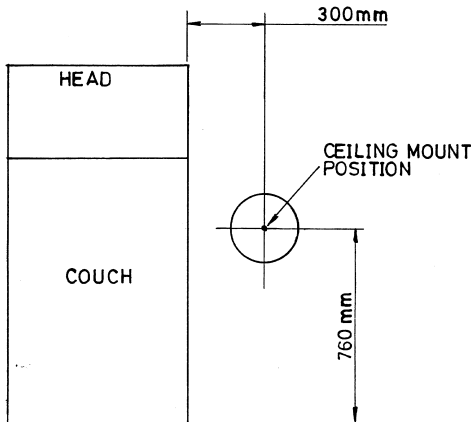

**WARNING: the light-head operates from a low-voltage supply produced by a transformer in the ceiling mount assembly and fed through the suspension arm. On NO ACCOUNT should the arm be connected directly to mains voltages.**

## Fitting the ceiling plate

Remove the clamp bolts, safety bolt/nylon insert nut and the clamp. Keep these parts in a safe place for use later.

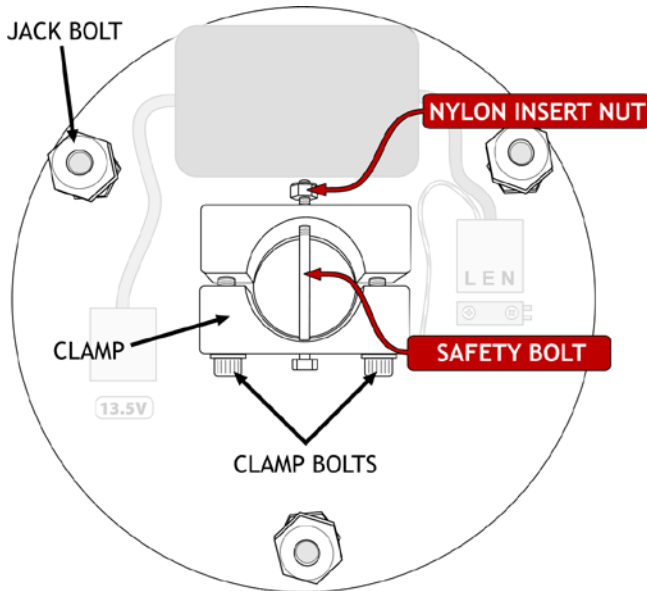

Fix the plate to the ceiling with bolts, screws or studs and nuts through the centre of each jack bolt. Do not fully tighten the fasteners at this point.

**Note: The nuts thread-locked to the upper end of the 3 jack bolts act as pressure pads. These pressure pads must be seated firmly against the mounting surface.**

**The jack bolts can then be used to adjust the position of the ceiling plate and down-tube.**

## Fitting the Down-tube

A 1 metre length of down-tube is included with all ceiling mount kits, and must be securely fitted in accordance with these instructions.

The down-tube should be cut to length on-site to suit the particular ceiling height and application.

Note when installed the down-tube must leave clearance above the ceiling mount plate to prevent the cable being trapped.

For determining the cut point, we suggest measuring the distance between the ceiling mounting plate, and a point about 1900mm above the floor.

The length of the down-tube should be altered to suit the room dimensions and the particular application for which the light is to be used.

**De-burr as necessary.**

**NOTE:** For suspended ceilings, the ceiling hole trim and retaining band should be placed over the downtube BEFORE proceeding.

Loosely refit the clamp and clamp bolts. Fit the down-tube in the clamp and tighten the clamp bolts to firmly hold it in place. Drill a 6mm hole completely through the tube via the guide holes in the clamp and fit the safety bolt and nylon insert lock nut supplied.

**NOTE: TO ENSURE THE USER'S SAFETY, THE SAFETY BOLT AND NYLON INSERT LOCK NUT MUST BE FITTED PROPERLY**

Feed the end of the low-voltage cable assembly through the tube.

Tighten both clamp screws fully and evenly until the tube is firmly clamped.

Adjust the 3 large bolts such that the down-tube is absolutely vertical. Tighten the fixing bolts or screws to firmly clamp the jack bolts tight against the joist, tighten the thin locknuts and re-check that the down-tube remains vertical, and the mounting plate has no movement. If necessary, repeat the adjustment.

Run the low-voltage cable to the mounted power-supply module, feed it through the grommet on the top of the module and connect it to the 2-way terminal block wired to the low-voltage output from the transformer.

Refit the module to its mounted rear plate.

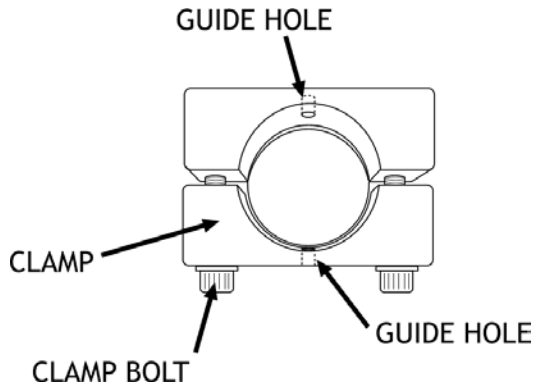

**NOTE:** For suspended ceilings cut a clearance hole in a ceiling tile, replace the tile and slide the trim up the downtube until it is firmly against ceiling tile, then roll the trim retaining band upward until it holds the trim in position.

**NOTE:** For conventional ceilings fit the cover, holding it in place with the retaining band from the fitting kit.

## Install the primary arm



To ensure the smooth rotation of the arm, it is essential that the primary arm spigot is **lightly** lubricated before assembly. A sachet of silicon grease is provided.

Place the nylon washer over the primary arm spigot.

Insert the primary arm spigot into the down-tube.

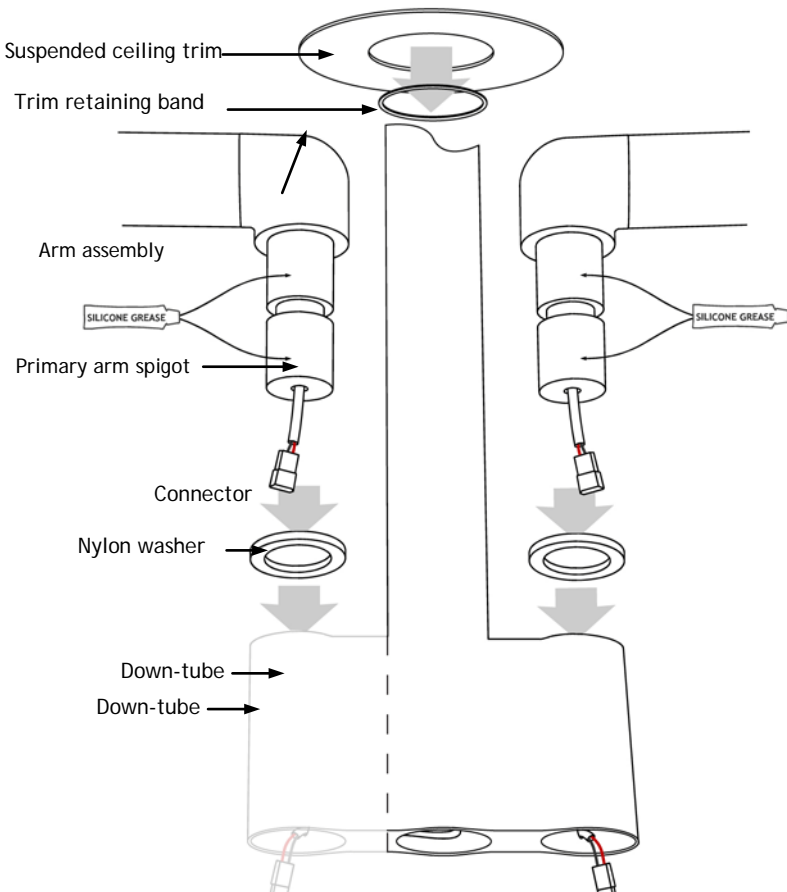

Join the connector from the primary arm to the connector from the down-tube.

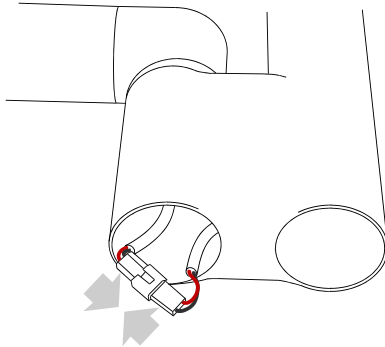

Fit the supplied bungs.

**Make sure to sit the joined connectors inside the bung before fitting to prevent the cable from being damaged.**

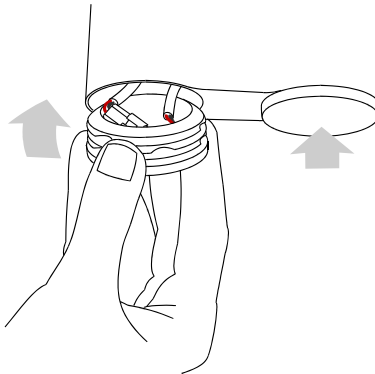

Fit the jib-joint cover (see p.20).

Fit the light-head (see p.21).

Check everything for tightness and safety.

Check the arm and head for freedom of movement.

Rebalance the jib arm if necessary (see p.9).

## Wiring the Wavelite (ceiling mount)

Provide a suitable, earthed switched fused spur.

Run a 1.5mm<sup>2</sup> twin and earth cable to the ceiling plate 230V terminal block.

Provide power to the spur.

Turn on the light with the rocker switch on its mounting swivel (see section 3 *Operation*) and check that the light illuminates.

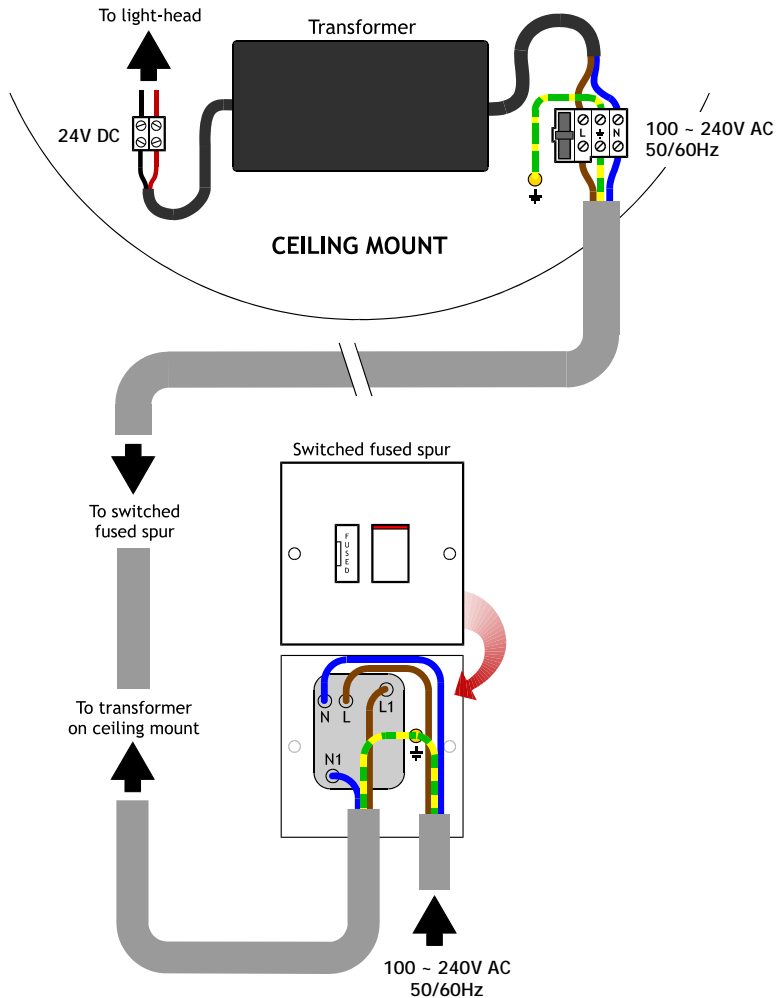

Wavelite (ceiling mount) wiring diagram



## Installation - Wall Mount

**CAUTION: this product must be earthed.**

Check you have the following items:

Wall-mount plate
Light-head on suspension arm
Power supply module

Determine where to mount the wall bracket. For general medical examination use, we suggest that the top of the bracket where the primary arm fits into should be about 2000mm above the floor. For other specific applications, mount the wall bracket in a location so that, when fitted, the light-head is at the required height.

**WARNING: Consult a building engineer, if in doubt.**

Secure the plate to the wall, ensuring that it is truly vertical.

**WARNING: the light-head operates from a low-voltage supply produced by a transformer in the power-supply module and fed through the suspension arm. On NO ACCOUNT should the arm be connected directly to mains electricity.**

Fit the power-supply module directly under the wall plate.

Remove the rear plate from the power-supply module by slackening the screw in each of the 4 corners.



To ensure the smooth rotation of the arm, **lightly** grease the spigot on the primary arm with the silicone grease provided. Slide the spigot into the bracket on the wall-mount plate, feeding the low-voltage cable from the primary arm through the top of the power-supply module.

Connect the low-voltage cable to the **2-way** terminal block wired to the low-voltage output from the transformer.

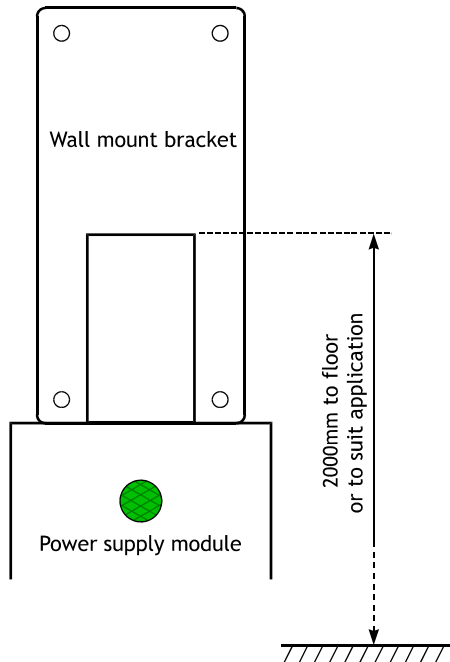

The power-supply module requires an earthed 230V AC electrical supply either fed into its rear or into a socket/switched fused spur on the side depending on the module supplied.

Connect the incoming mains cable to the **3-way** 'LEN' terminal block in the module.

Fasten the module's earth-bond wire to the rear-plate's earth stud.

Refit the module to its mounted rear plate.

Fit the jib-joint cover (see p.20).

Fit the light-head (see p.21).

Check everything for tightness and safety.

Check the arm and head for freedom of movement.

Rebalance the jib arm, if necessary.

Provide power to the power-supply module and check that the mains indicator illuminates.

Operate the variable intensity control module by pressing it. Rotate to dim. Check that the light-head illuminates and that the intensity control works.

## Assembly - Mobile Mount

Fit the lower section of the up-stand to the base, mating the locating peg on the lower up-stand section with its associated hole on the base.

Fit the socket-head screw through the screw cover base and screw tightly into the up-stand using a hex wrench.

Fit the screw cover cap.

Refer to the 'peel-off' assembly marks as shown.

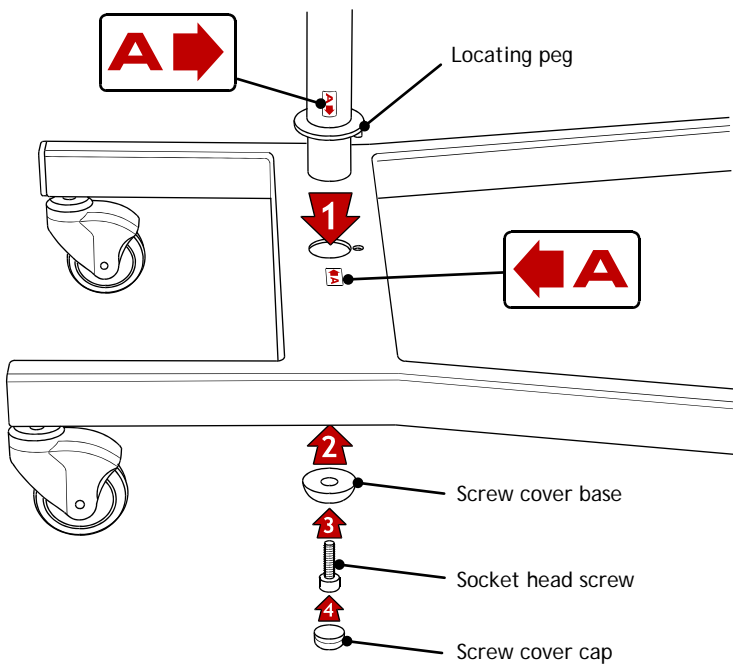

Fit the upper section of the up-stand to the lower section of the up-stand with the screw and shake-proof washer using the hex wrench provided.

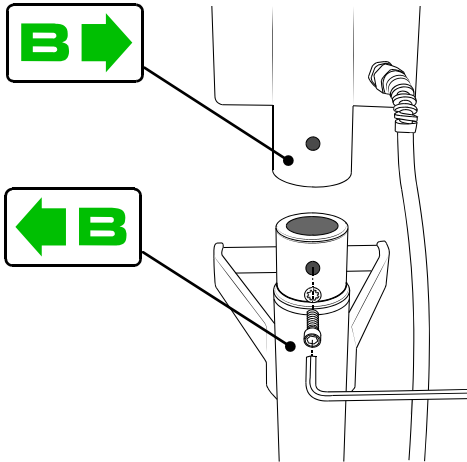

Wrap the flex around the cable holders

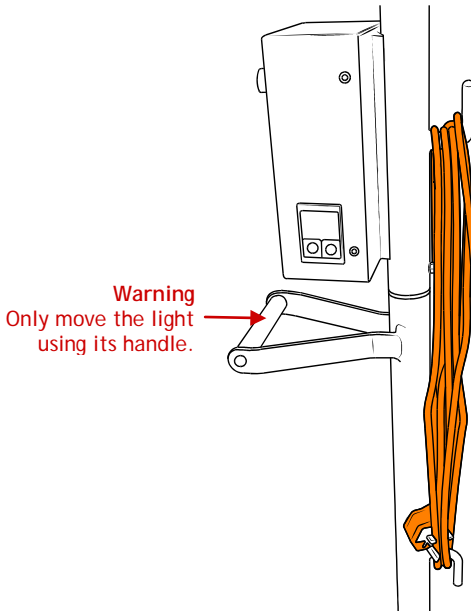

Fit the jib-joint cover (see p.20).

Fit the light-head (see p.21).

## Installation - Fit the jib-joint cover

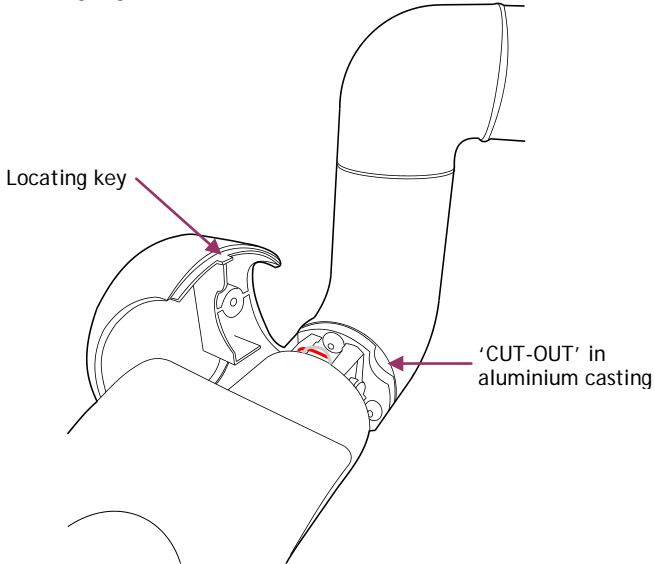

1. Covers are marked 'L' and 'R' on their inside faces as viewed from the end of arm. Engage the slider, with its 'T' mark uppermost, into the groove inside the cover.

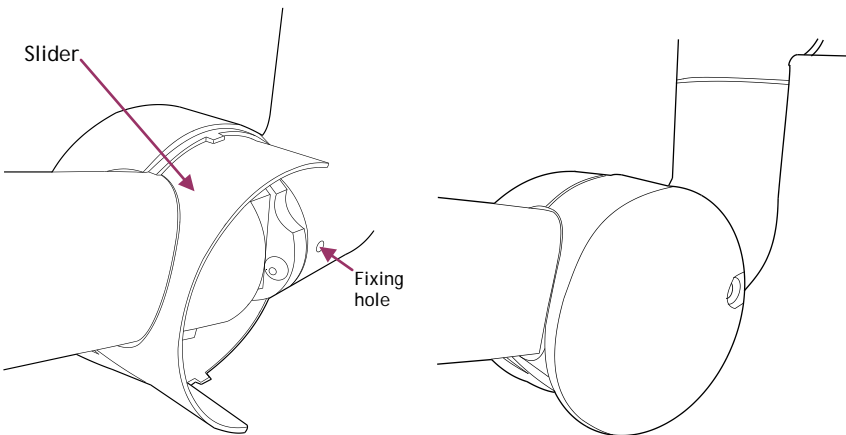

2. Align holes in cover and painted elbow. 'Nip up' the screw to secure.  
**DO NOT OVERTIGHTEN**
3. Fit opposite cover  
**DO NOT OVERTIGHTEN**  
Fit a plug in each hole
4. Carefully check the operation of arm and the jib-joint cover.

## Installation - Fitting the light-head

Connect the light-head connector to the connector in the arm

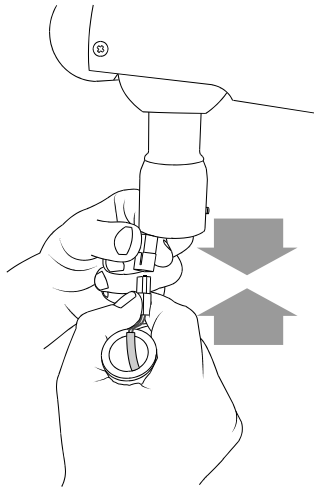

Apply a little grease to the light-head spigot and insert it into the arm, being careful not to trap the cable/connector.

Supporting the light-head in one hand, tighten the locking grub-screw with the hex key provided.

**NOTE: Make sure the grub-screw is not too tight preventing the light-head from rotating.**

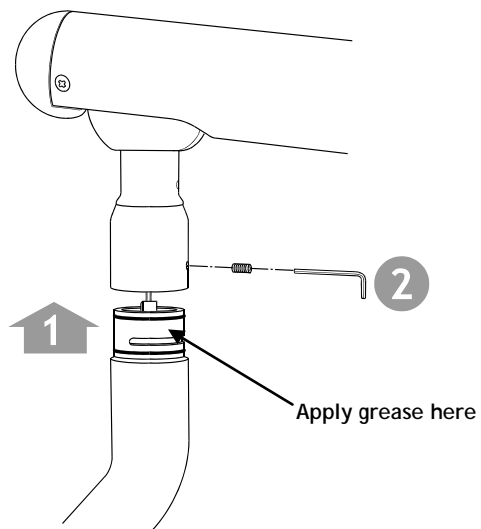

## 7. FUSE REPLACEMENT

### Mobile version only

**CAUTION:** fuses normally blow for a reason.  
Investigate likely faults before changing fuses.

**CAUTION:** isolate the unit from the mains before accessing the fuses.

Both the live and neutral mains inputs are fused. The fuses are contained in a holder which is part of the IEC inlet mounted on the rear panel of the mobile base.

Using a flat-blade screwdriver, or similar, pull forward the 'drawer' containing the fuses.

Hinge down the front of the holder.

Lift the fuses by pushing them through the holes below them.

Refit new fuses and reverse the removal sequence, ensuring the 'drawer' is pushed fully home.

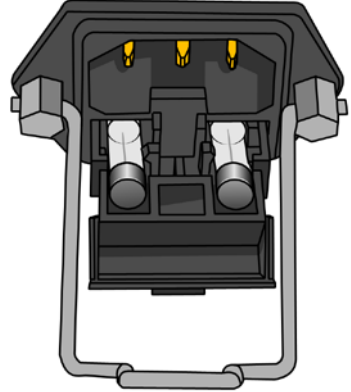

## 8. SPARE PARTS

**CAUTION:** Use only genuine DARAY replacement lamps as other types may seriously impair the optical performance of the product.

ITEM NO	PART NAME	TYPE	PART NO
1	Fuse	1A 20mm	D10873
2	Microfibre cloth	5 pack	DRK4080

## Returns Policy

### IMPORTANT!

Before returning your item, you must call us on 0844 375 9000

We want you to be completely satisfied with your purchase. If you need to return goods purchased from DARAY Ltd, please read the following information carefully.

The DARAY Ltd returns policy provides guidance on when you can return goods we have supplied, and what you can expect from us once you do. To see our detailed returns policy and procedure visit [www.daray.co.uk/returns](http://www.daray.co.uk/returns)

TYPE OF RETURN	REMEDY
<b>DAMAGED GOODS OR DOA*</b> Goods which are physically damaged on delivery, or which do not function.	We must be notified within 24 hours of receipt.
<b>GOODS DEVELOPING A FAULT</b> Goods which have developed a fault within the warranty period.	Within 14 days of delivery we will replace the item as DOA*. If the fault develops after 14 days, but within the warranty period, we will initiate the returns procedure.
<b>NON WARRANTY</b> Goods which have developed a fault outside the warranty period.	If a fault develops outside the warranty period, we will initiate the returns procedure.
<b>OTHER</b> Any situation which is not covered by the above.	We will try to help, but we cannot normally offer a refund.

\*DOA - dead on arrival

For additional clarification, please refer to our terms and conditions at [www.daray.co.uk/terms](http://www.daray.co.uk/terms).

In a small number of cases, we may determine that a replacement would not work any better than the original product we supplied. In such cases we will only offer a refund rather than a replacement for qualifying returns.

Replacement bulbs are not eligible for returns, unless they are faulty or damaged.

Spare parts ordered on our website or from supplied part codes are not be eligible for credit. We will accept returns and exchange for the correct item.

If you purchase an item incorrectly you can return it within 14 days and it can be exchanged for another product of equal or high value, excluding transportation charges incurred.

If you send us goods that do not qualify for return, you will invalidate your claim to any refund, and you will be obliged to compensate DARAY Ltd for the cost of return postage and any other reasonable costs incurred processing the goods.

Your statutory rights are not affected.

# Warranty

## TERMS AND CONDITIONS OF WARRANTY

1. To qualify for this warranty you must register on [www.daray.co.uk](http://www.daray.co.uk) or return to Daray Ltd (Daray) the duly completed warranty-registration form accompanying the product.
2. Daray warrants this product (excluding lamp) against faulty material and workmanship during the period of the warranty. The period of warranty is the period stated on your warranty card and commences on the date of purchase of the product. In the event that the product is not in good working order Daray will provide, during the warranty period, a free repair service within the United Kingdom. The warranty is subject to proof of purchase being provided; therefore, you should retain your original receipt.
  - 2.1 The repair service consists of the provision of spare parts and/or replacement products (at Daray's discretion) which will be provided on an exchange basis and will either be new, equivalent to new or reconditioned. All replaced spare parts and products shall become the property of Daray.
  - 2.2 Daray's only obligation under this warranty is the provision of the service as set out above.
  - 2.3 All products are returned to Daray at the customer's cost and risk. Products to be returned should be adequately packed. For the address to send returns to please visit [www.daray.co.uk](http://www.daray.co.uk)
3. Daray's arrangements for providing service provided under this warranty may include the use of sub-contractors.
4. This warranty does not cover damage or defects in the Product caused by or resulting from:
  - Wilful neglect or negligence by anyone other than Daray;
  - Improper use, storage or handling of the product;
  - Use of non-Daray approved parts (such as replacement lamps) not compatible with the Product;
  - Fire, accident or disaster;
  - Use of non-Daray modifications other than in accordance with Daray's instructions;Attachment of fittings and accessories not approved by Daray;  
Repairs, modifications carried out by service personnel not approved by Daray;
  - Damage caused by chemical corrosion from cleaning agents not approved by Daray.
  - Failure to use or install the product in accordance with the manufacturer's instructions.
5. Nothing in this warranty shall have the effect of restricting or excluding the liability of Daray in respect of:
  - a) Death and personal injury caused by the negligence of Daray, or for fraud;
  - b) Under the *Consumer Protection Act 1987* to a person who has suffered damage caused by a defective product or to a dependant or relative of such a person;
  - c) Direct damage to your property caused by the proven negligence of Daray.
6. This agreement does not give any rights other than those expressly set out above and in particular, Daray will not be responsible for any loss of income, profits or contracts or any direct or indirect consequential loss, damage caused to or suffered by the purchaser as a direct result of this agreement.
7. This warranty is offered (subject to these terms and conditions) in addition to, and does not affect your statutory rights.
8. Daray may disclose your details and other personal information to companies within the Daray group including any subsidiary company or sub contractor of Daray for the purposes of performing our obligations hereunder.
9. You must not resell outside the UK any products supplied by Daray and covered by the *Export of Goods (Control) Order 1992* (or any law that replaces it) without obtaining all necessary licences. You also agree not to sell the product in the UK if you know or think that the person buying the product intends to export it without getting the necessary licences. You agree to impose similar conditions to these on anyone you sell the product to.
10. These conditions shall in all respect be governed and construed in accordance with English law and the exclusive jurisdiction of the English courts.





# DARAY®

WARRANTY REGISTRATION  
TO VALIDATE YOUR WARRANTY  
PLEASE COMPLETE IN BLOCK CAPITALS  
AND RETURN IN A WINDOWED DL ENVELOPE  
TO OUR FREEPOST ADDRESS

**ALTERNATIVELY REGISTER ONLINE AT [WWW.DARAY.COM](http://WWW.DARAY.COM)**



## 3 YEAR AFTERCARE PLAN

NAME:
COMPANY:
EMAIL:
PHONE:
FAX:

ADDRESS:
----------

PURCHASED FROM:
-----------------

DATE OF PURCHASE:
-------------------

Freepost Plus RRAS-YGXE-SLBC  
Daray Ltd  
Marquis Drive  
SWADLINCOTE  
DE12 6EJ

Occasionally DARAY would like to send you information about our special offers and promotions. If you do not wish to receive such information, please tick here:

Privacy statement: DARAY will not pass on your details to any third party.

PRODUCT:
SERIAL No:





Marquis Drive · Moira · Derbyshire · DE12 6EJ  
Tel: 0844 375 9000 · Fax: 0333 321 0973  
info@daray.co.uk · www.daray.co.uk