

DARAY®



MAG500series **MAGNIFYING LIGHT**

QAM.MAG500.0909.2

DARAY®

INSTALLATION		
1.	ASSEMBLY INSTRUCTIONS	4
2.	CLAMP ASSEMBLY	5
3	REPLACEMENT LAMP	5
4.	ATTENTION	5
	RETURNS POLICY	6
	WARRANTY	7
	WARRANTY REGISTRATION	9

Tel: 0844 375 9000 Fax: 0333 321 0973
info@daray.com • www.daray.com

1. ASSEMBLY

1. Turn the T-bar (5) of the desk-clamp to adjust it to the required size, fit to desk edge and tighten
2. Remove the desk-clamp safety screw (4)
3. Insert the magnifier base pivot post into the desk-clamp (3)
4. Replace the desk-clamp safety screw (4)
5. To move the magnifier's position, loosen the locking wheels (2), move the lamp to the ideal position then re-tighten the locking wheels

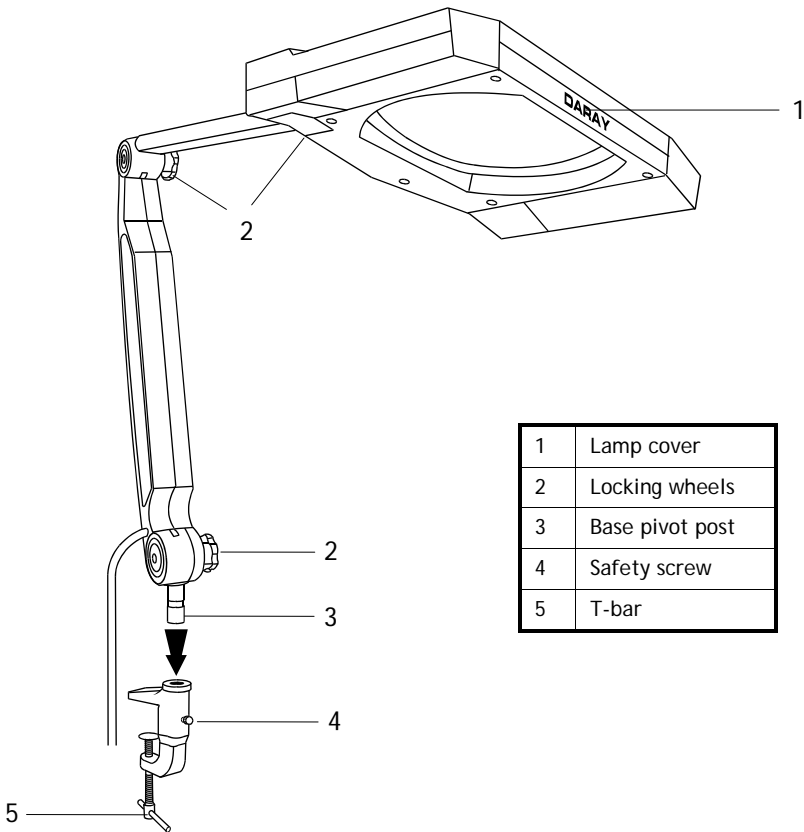

fig. 1

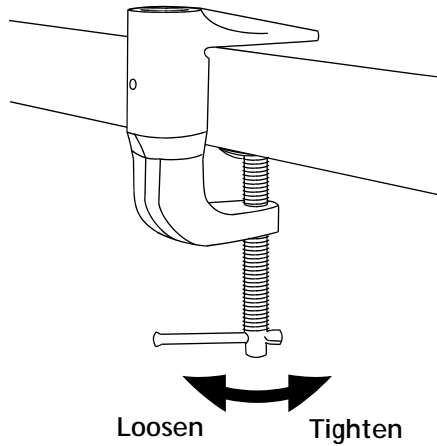

fig. 2

2. LAMP REPLACEMENT

1. Turn the lamp off
2. Disconnect the power plug
3. Allow the magnifier to cool
4. Remove the lamp cover (1)
5. Replace lamp with LBMA500 7W fluorescent
6. Replace the lamp cover
7. Reconnect the power plug and turn on

3. CLEANING

1. Turn the lamp off
2. Disconnect the power plug
3. Allow the magnifier to cool
4. Use a soft lint free cloth to clean

4. ATTENTION!

If the flexible power cable should become damaged, it should only be replaced by the manufacturer or a qualified electrician.

Returns Policy

IMPORTANT!

Before returning your item, you must call us on 0844 375 9000

We want you to be completely satisfied with your purchase. If you need to return goods purchased from DARAY Ltd, please read the following information carefully.

The DARAY Ltd returns policy provides guidance on when you can return goods we have supplied, and what you can expect from us once you do. To see our detailed returns policy and procedure visit www.daray.co.uk/returns

TYPE OF RETURN	REMEDY
DAMAGED GOODS OR DOA* Goods which are physically damaged on delivery, or which do not function.	We must be notified within 24 hours of receipt.
GOODS DEVELOPING A FAULT Goods which have developed a fault within the warranty period.	Within 14 days of delivery we will replace the item as DOA*. If the fault develops after 14 days, but within the warranty period, we will initiate the returns procedure.
NON WARRANTY Goods which have developed a fault outside the warranty period.	If a fault develops outside the warranty period, we will initiate the returns procedure.
OTHER Any situation which is not covered by the above.	We will try to help, but we cannot normally offer a refund.

*DOA - dead on arrival

For additional clarification, please refer to our terms and conditions at www.daray.co.uk/terms.

In a small number of cases, we may determine that a replacement would not work any better than the original product we supplied. In such cases we will only offer a refund rather than a replacement for qualifying returns.

Replacement bulbs are not eligible for returns, unless they are faulty or damaged.

Spare parts ordered on our website or from supplied part codes are not be eligible for credit. We will accept returns and exchange for the correct item.

If you purchase an item incorrectly you can return it within 14 days and it can be exchanged for another product of equal or high value, excluding transportation charges incurred.

If you send us goods that do not qualify for return, you will invalidate your claim to any refund, and you will be obliged to compensate DARAY Ltd for the cost of return postage and any other reasonable costs incurred processing the goods.

Your statutory rights are not affected.

WARRANTY

TERMS AND CONDITIONS OF WARRANTY

1. To qualify for this warranty you must register on www.daray.co.uk or return to Daray Ltd (Daray) the duly completed warranty-registration form accompanying the product.
2. Daray warrants this product (excluding lamp) against faulty material and workmanship during the period of the warranty. The period of warranty is the period stated on your warranty card and commences on the date of purchase of the product. In the event that the product is not in good working order Daray will provide, during the warranty period, a free repair service within the United Kingdom. The warranty is subject to proof of purchase being provided; therefore, you should retain your original receipt.
 - 2.1 The repair service consists of the provision of spare parts and/or replacement products (at Daray's discretion) which will be provided on an exchange basis and will either be new, equivalent to new or reconditioned. All replaced spare parts and products shall become the property of Daray.
 - 2.2 Daray's only obligation under this warranty is the provision of the service as set out above.
 - 2.3 All products are returned to Daray at the customer's cost and risk. Products to be returned should be adequately packed. For the address to send returns to please visit www.daray.co.uk
3. Daray's arrangements for providing service provided under this warranty may include the use of sub-contractors.
4. This warranty does not cover damage or defects in the Product caused by or resulting from:
 - Wilful neglect or negligence by anyone other than Daray;
 - Improper use, storage or handling of the product;
 - Use of non-Daray approved parts (such as replacement lamps) not compatible with the Product;
 - Fire, accident or disaster;
 - Use of non-Daray modifications other than in accordance with Daray's instructions;Attachment of fittings and accessories not approved by Daray;
Repairs, modifications carried out by service personnel not approved by Daray;
 - Damage caused by chemical corrosion from cleaning agents not approved by Daray.
 - Failure to use or install the product in accordance with the manufacturer's instructions.
5. Nothing in this warranty shall have the effect of restricting or excluding the liability of Daray in respect of:
 - a) Death and personal injury caused by the negligence of Daray, or for fraud;
 - b) Under the *Consumer Protection Act 1987* to a person who has suffered damage caused by a defective product or to a dependant or relative of such a person;
 - c) Direct damage to your property caused by the proven negligence of Daray.
6. This agreement does not give any rights other than those expressly set out above and in particular, Daray will not be responsible for any loss of income, profits or contracts or any direct or indirect consequential loss, damage caused to or suffered by the purchaser as a direct result of this agreement.
7. This warranty is offered (subject to these terms and conditions) in addition to, and does not affect your statutory rights.
8. Daray may disclose your details and other personal information to companies within the Daray group including any subsidiary company or sub contractor of Daray for the purposes of performing our obligations hereunder.
9. You must not resell outside the UK any products supplied by Daray and covered by the *Export of Goods (Control) Order 1992* (or any law that replaces it) without obtaining all necessary licences. You also agree not to sell the product in the UK if you know or think that the person buying the product intends to export it without getting the necessary licences. You agree to impose similar conditions to these on anyone you sell the product to.
10. These conditions shall in all respect be governed and construed in accordance with English law and the exclusive jurisdiction of the English courts.

DARAY[®]

WARRANTY REGISTRATION
TO VALIDATE YOUR WARRANTY
PLEASE COMPLETE IN BLOCK CAPITALS
AND RETURN IN A WINDOWED DL ENVELOPE
TO OUR FREEPOST ADDRESS

ALTERNATIVELY REGISTER ONLINE AT WWW.DARAY.COM



3 YEAR AFTERCARE PLAN

NAME:
COMPANY:
EMAIL:
PHONE:
FAX:

ADDRESS:

PURCHASED FROM:

DATE OF PURCHASE:

Freepost Plus RRAS-YGXE-SLBC
Daray Ltd
Marquis Drive
SWADLINCOTE
DE12 6EJ

Occasionally DARAY would like to send you information about our special offers and promotions. If you do not wish to receive such information, please tick here:

Privacy statement: DARAY will not pass on your details to any third party.

PRODUCT:
SERIAL No:

Marquis Drive · Moira · Derbyshire · DE12 6EJ
Tel: 0844 375 9000 · Fax: 0333 321 0973
email: info@daray.co.uk · url: www.daray.co.uk