

# **DARAY<sup>®</sup>**

## **HEALTHCARE PRODUCTS**

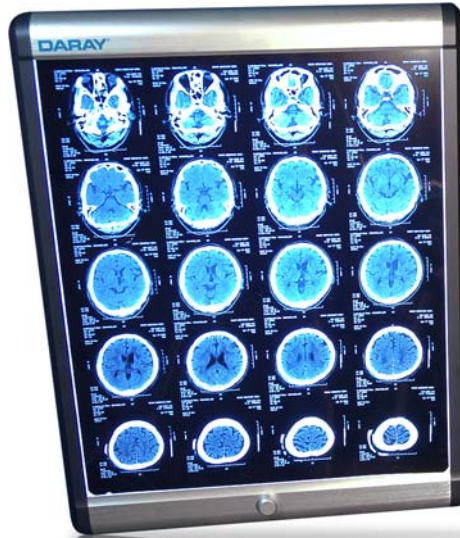

# **DX4500 SERIES X-RAY FILM VIEWERS OPERATING MANUAL**

QAM/DX4500\_Issue 2 06/09



# **DARAY<sup>®</sup>**

## **HEALTHCARE PRODUCTS**

1. GENERAL DESCRIPTION	4
2. SPECIFICATION	4
3. MOUNTING	6
4. OPERATION	6
5. MAINTENANCE	6
RETURNS POLICY	7
WARRANTY	8
WARRANTY REGISTRATION	9

Tel: 0870 777 2664 Fax: 0870 777 2665  
email: [info@daray.co.uk](mailto:info@daray.co.uk) url: [www.daray.co.uk](http://www.daray.co.uk)

## 1. GENERAL DESCRIPTION

Daray's DX4500 uses LCD screen technology to produce uniform illumination in an extremely slim and lightweight case. External-electrode fluorescent lamps are used to give extended life and efficient power consumption. Single, double, triple and quadruple models are available.

The viewer has an intensity control so its user can set the optimum light level for interpreting different film types.

## 2. SPECIFICATION

	DX4501 SINGLE	DX4502 DOUBLE	DX4503 TRIPLE	DX4504 QUADRUPLE
Input voltage	90-260V 50/60Hz			
Power consumption	45VA	90VA	135VA	180VA
Lamp type	EEFL			
Lamp life (typical)	7 years			
Luminance	7,000-12,000 lux , variable, per panel			
Uniformity	90% min			
Mass (kg) approx	4.8	9.6	14.4	19.2

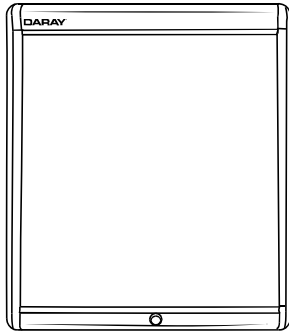

DX4501

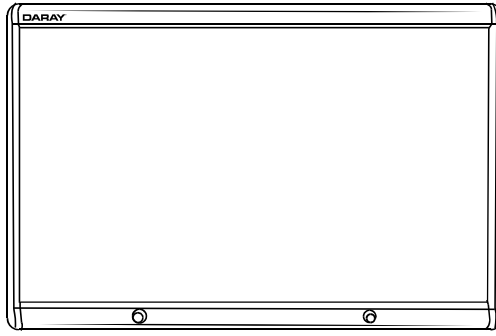

DX4502

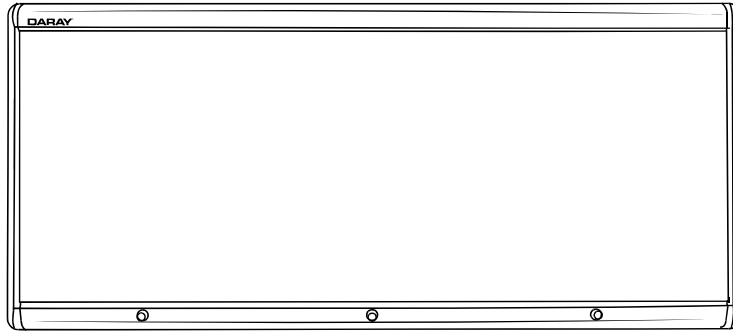

DX4503

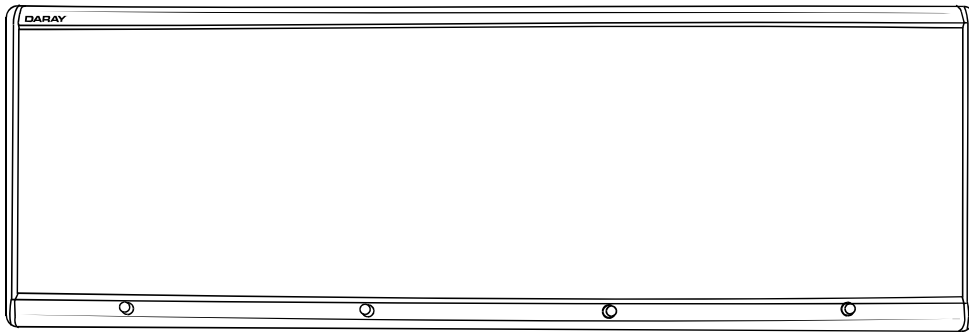

DX4504

### 3. MOUNTING

Determine where the viewer should be mounted, bearing in mind the availability of a mains electricity socket.

Fix 2 suitable screws into the wall at the correct spacing and hang the viewer onto the screws via the keyhole slots in its rear panel.

### 4. OPERATION

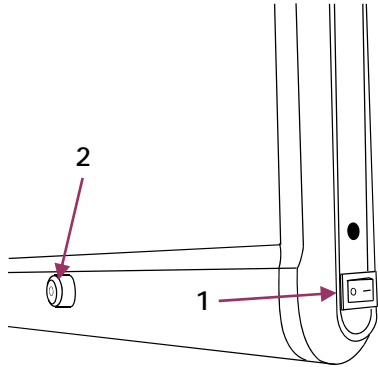

Plug the mains lead into a standard 13A socket. Switch on the rocker switch (1) on the bottom of the viewer's right-hand side. Turn the viewer on and adjust its intensity using the rotary control (2) on its front.

**PLEASE NOTE:** the type of lamp used in this viewer takes a few minutes to 'warm up', the exact time depending on the ambient temperature.

Switch the viewer off when it is not in use, and unplug the mains plug, if the viewer is not to be used for an extended period.

### 5. MAINTENANCE

The viewer should be dusted with a soft flannel cloth, and the screen gently cleaned with an alcohol-based liquid, and wiped dry.

**NO ABRASIVE CLEANING MATERIALS OR ORGANIC SOLVENTS SUCH AS THINNERS OR ETHYLENE SHOULD BE USED TO CLEAN ANY PART OF THE VIEWER.**

PLEASE REFER ANY PROBLEMS INITIALLY TO YOUR DISTRIBUTOR.  
DARAY CUSTOMER SERVICES ON 0870 777 2664 ARE AVAILABLE TO ASSIST WITH ANY PROBLEMS THE DISTRIBUTOR CANNOT SOLVE.

## Returns Policy

**IMPORTANT!**  
Before returning your item, you must call us on 0870 199 4299

We want you to be completely satisfied with your purchase. If you need to return goods purchased from DARAY Ltd, please read the following information carefully.

The DARAY Ltd returns policy provides guidance on when you can return goods we have supplied, and what you can expect from us once you do. To see our detailed returns policy and procedure visit [www.daray.co.uk/returns](http://www.daray.co.uk/returns)

TYPE OF RETURN	REMEDY
<b>DAMAGED GOODS OR DOA*</b> Goods which are physically damaged on delivery, or which do not function.	We must be notified within 24 hours of receipt.
<b>GOODS DEVELOPING A FAULT</b> Goods which have developed a fault within the warranty period.	Within 14 days of delivery we will replace the item as DOA*. If the fault develops after 14 days, but within the warranty period, we will initiate the returns procedure.
<b>NON WARRANTY</b> Goods which have developed a fault outside the warranty period.	If a fault develops outside the warranty period, we will initiate the returns procedure.
<b>OTHER</b> Any situation which is not covered by the above.	We will try to help, but we cannot normally offer a refund.

\*DOA - dead on arrival

For additional clarification, please refer to our terms and conditions at [www.daray.co.uk/terms](http://www.daray.co.uk/terms).

In a small number of cases, we may determine that a replacement would not work any better than the original product we supplied. In such cases we will only offer a refund rather than a replacement for qualifying returns.

Replacement bulbs are not eligible for returns, unless they are faulty or damaged.

Spare parts ordered on our website or from supplied part codes are not be eligible for credit. We will accept returns and exchange for the correct item.

If you have incorrectly ordered a product and it is unopened and in perfect condition, within seven days of the original order you may order the correct product and receive a full credit for the returned item. In all other cases, items returned for credit are subject to a 25% restocking fee.

If you send us goods that do not qualify for return, you will invalidate your claim to any refund, and you will be obliged to compensate DARAY Ltd for the cost of return postage and any other reasonable costs incurred processing the goods.

Your statutory rights are not affected.

## WARRANTY

### TERMS AND CONDITIONS OF WARRANTY

1. To qualify for this warranty you must register on [www.daray.co.uk](http://www.daray.co.uk) or return to Daray Ltd (Daray) the duly completed warranty-registration form accompanying the product.
2. Daray warrants this product (excluding lamp) against faulty material and workmanship during the period of the warranty. The period of warranty is the period stated on your warranty card and commences on the date of purchase of the product. In the event that the product is not in good working order Daray will provide, during the warranty period, a free repair service within the United Kingdom. The warranty is subject to proof of purchase being provided; therefore, you should retain your original receipt.
  - 2.1 The repair service consists of the provision of spare parts and/or replacement products (at Daray's discretion) which will be provided on an exchange basis and will either be new, equivalent to new or reconditioned. All replaced spare parts and products shall become the property of Daray.
  - 2.2 Daray's only obligation under this warranty is the provision of the service as set out above.
  - 2.3 All products are returned to Daray at the customer's cost and risk. Products to be returned should be adequately packed. For the address to send returns to please visit [www.daray.co.uk](http://www.daray.co.uk)
3. Daray's arrangements for providing service provided under this warranty may include the use of sub-contractors.
4. This warranty does not cover damage or defects in the Product caused by or resulting from:
  - Wilful neglect or negligence by anyone other than Daray;
  - Improper use, storage or handling of the product;
  - Use of non-Daray approved parts (such as replacement lamps) not compatible with the Product;
  - Fire, accident or disaster;
  - Use of non-Daray modifications other than in accordance with Daray's instructions;Attachment of fittings and accessories not approved by Daray;  
Repairs, modifications carried out by service personnel not approved by Daray;
  - Damage caused by chemical corrosion from cleaning agents not approved by Daray.
  - Failure to use or install the product in accordance with the manufacturer's instructions.
5. Nothing in this warranty shall have the effect of restricting or excluding the liability of Daray in respect of:
  - a) Death and personal injury caused by the negligence of Daray, or for fraud;
  - b) Under the *Consumer Protection Act 1987* to a person who has suffered damage caused by a defective product or to a dependant or relative of such a person;
  - c) Direct damage to your property caused by the proven negligence of Daray.
6. This agreement does not give any rights other than those expressly set out above and in particular, Daray will not be responsible for any loss of income, profits or contracts or any direct or indirect consequential loss, damage caused to or suffered by the purchaser as a direct result of this agreement.
7. This warranty is offered (subject to these terms and conditions) in addition to, and does not affect your statutory rights.
8. Daray may disclose your details and other personal information to companies within the Daray group including any subsidiary company or sub contractor of Daray for the purposes of performing our obligations hereunder.
9. You must not resell outside the UK any products supplied by Daray and covered by the *Export of Goods (Control) Order 1992* (or any law that replaces it) without obtaining all necessary licences. You also agree not to sell the product in the UK if you know or think that the person buying the product intends to export it without getting the necessary licences. You agree to impose similar conditions to these on anyone you sell the product to.
10. These conditions shall in all respect be governed and construed in accordance with English law and the exclusive jurisdiction of the English courts.

# DARAY<sup>®</sup>

## HEALTHCARE PRODUCTS

WARRANTY REGISTRATION  
TO VALIDATE YOUR WARRANTY  
PLEASE COMPLETE IN BLOCK CAPITALS  
AND RETURN IN A WINDOWED DL ENVELOPE  
TO OUR FREEPOST ADDRESS

**ALTERNATIVELY REGISTER ONLINE AT [WWW.DARAY.COM](http://WWW.DARAY.COM)**



## 1 YEAR WARRANTY

NAME:	
COMPANY:	
EMAIL:	
PHONE:	
FAX:	

Freepost Plus RRAS-YGXE-SLBC  
Daray Ltd  
Marquis Drive  
SWADLINCOTE  
DE12 6EJ

ADDRESS:

--

PURCHASED FROM:

--

DATE OF PURCHASE:

--

Occasionally DARAY would like to send you information about our special offers and promotions. If you do not wish to receive such information, please tick here:

Privacy statement: DARAY will not pass on your details to any third party.

PRODUCT:
SERIAL No:





**DARAY**<sup>®</sup>  
HEALTHCARE PRODUCTS

**ILLUMIN**<sup>8</sup><sup>™</sup>

**MEDISYS**<sup>®</sup>

**I****MAGNIFY**<sup>®</sup>

**VitalSignZ**<sup>™</sup>

**LifeSignZ**<sup>™</sup>

**BioSignZ**<sup>™</sup>

**NfuZe**<sup>™</sup>

**VetZ**<sup>™</sup>

 **BioProtect**<sup>®</sup>  
Antimicrobial protection

Marquis Drive · Moira · Derbyshire · DE12 6EJ  
Tel: 0870 777 2664 · Fax: 0870 777 2665  
email: [info@daray.co.uk](mailto:info@daray.co.uk) · url: [www.daray.co.uk](http://www.daray.co.uk)