

# **DARAY<sup>®</sup>**

## **HEALTHCARE PRODUCTS**



# **BILITE**

## **UNIT, CEILING AND WALL MOUNTED OPERATING AND INSTALLATION MANUAL**

GAM.BILITE.1209.5



# DARAY<sup>®</sup>

## HEALTHCARE PRODUCTS

INSTALLATION		
1.	GENERAL DESCRIPTION	4
2.	SPECIFICATION	4
2.1	Serial numbers and labelling	4
2.2	Dimensions	5
3.	OPERATION	6
4.	MAINTENANCE, CLEANING AND DISINFECTION	7
4.1	Troubleshooting	7
4.2	Routine maintenance	8
5.	LAMP-BAR REPLACEMENT	9
6.	ADJUSTMENT OF ARM BALANCE TO ELIMINATE DRIFT	10
7.	INSTALLATION	11
7.1	Unit/chair mount with remote transformer	11
7.2	Ceiling mount	12
7.3	Wall mount	17
8.	FITTING THE LIGHT HEAD	20
	RETURNS POLICY	22
	WARRANTY	23
	WARRANTY REGISTRATION	25

Tel: 0844 375 9000 Fax: 0333 321 0973  
 info@daray.com • www.daray.com

# 1. GENERAL DESCRIPTION

DARAY's Bilite is the world-renowned dental operating light which employs twin-beam technology to eliminate shadows in the oral cavity. The light produces a wide, virtually cold, rectangular light patch with extremely sharp edges.

The light head is mounted on DARAY's sophisticated balanced suspension arm which is light to move and does not drift once positioned. The Bilite features variable-intensity control on the wall and ceiling-mounted models, and all versions operate from a safe, low voltage fed through the suspension arm to the light head.

DARAY's extremely quick and simple lamp-bar change is retained, allowing blown bulbs to be swapped quickly without risk of burnt fingers.

The ceiling or wall light comprises 4 parts: a mounting, a variable-intensity power-supply module, a suspension arm, and the light head. The power-supply module is fitted with an IEC inlet so the mains may be supplied via a plug-in flex from a standard mains socket. This arrangement can readily be converted using a parts kit supplied as standard for use where the mains-electrical supply cables are 'chased' into a wall. The power-supply module is fastened to the wall-mount bracket for the BLLW and can be screwed to the wall to power the BLLC.

The unit-mounted BLL comes with the light head, suspension arm and separate transformer for mounting with the chair-package utilities.

# 2. SPECIFICATION

Light intensity at 0.7m	0 - 26,000 lux
Colour temperature	3,600K
Patch size at 0.7m	300 x 200 mm
Operating voltage	12V AC
Input voltage	230V 50Hz, class 1 (earthed)
Arm reach	1650mm
Jib arm vertical movement	+15° to -45°
Bulb	12V 55W DARAY's part no: LB1024

## 2.1 Serial numbers and labelling

Each Bilite is allocated a unique serial number located on the inside of the slip-ring housing, and is identified by a label affixed to the power-supply module.

## 2.2 Dimensions

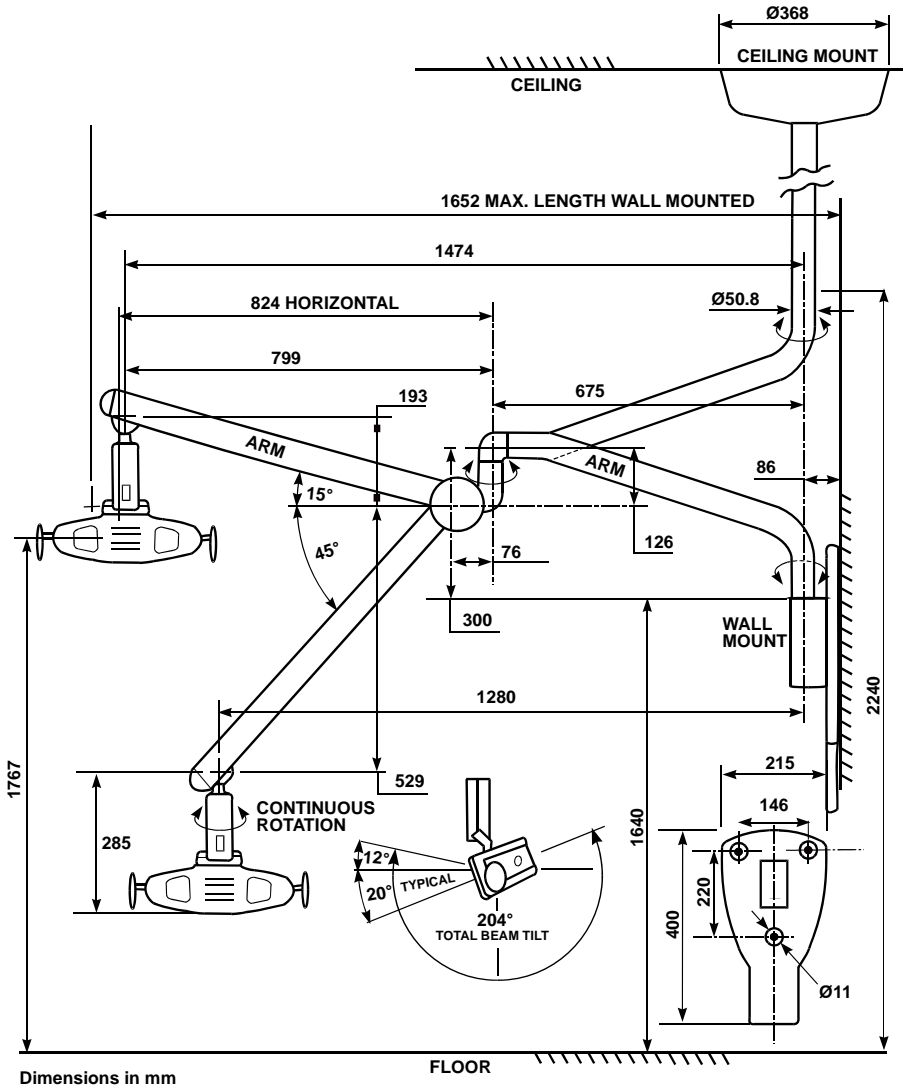

### 3. OPERATION

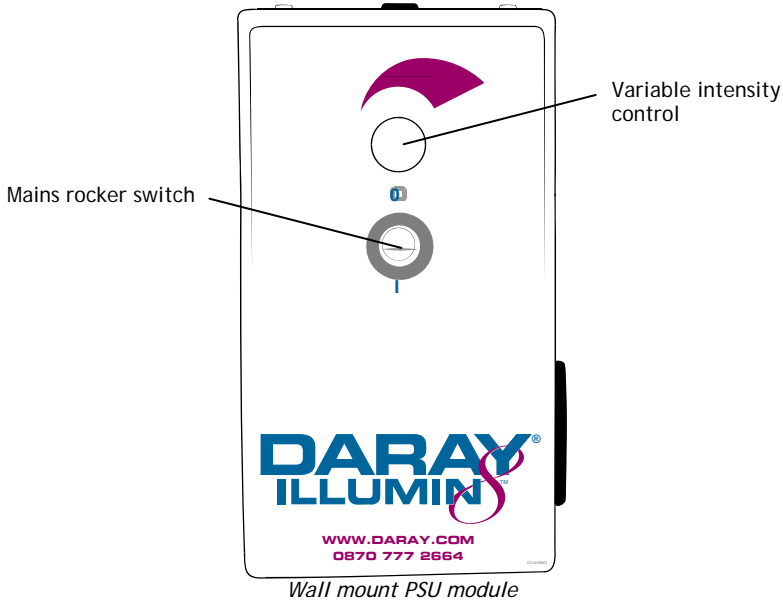

#### Wall mount

Turn on the mains rocker switch on the power-supply module. The switch should illuminate. If the switch does not illuminate, check the mains supply and then the fuses in the module, which are located on its right-hand side. For the versions powered via an IEC lead with a moulded mains plug, check the fuse in the mains plug.

Turn on the light using the switch on the head mounting. Set the required illumination level using the variable intensity control on the power-supply module.

#### Ceiling mount

Switch on at the switch fused spur. The indicator on the switch fused spur should illuminate.

Turn on the light using the switch on the head mounting. Set the required illumination level using the variable intensity control module.

If the Bilite does not illuminate, press the variable intensity control knob and then set the desired intensity.

#### All models

After use, switch off the power-supply module on the wall, as well as the light-head switch.

Use the handles to steer the light-patch to where you want it; the suspension arm swivels at the mounting and at the joint between the primary and jib arms. The jib arm allows the light-head to be moved up and down. The light-head itself can rotate 360° on the jib arm in its horizontal axis.

## 4. MAINTENANCE, CLEANING AND DISINFECTION

**WARNING! Do not use strong chemical cleaning agents such as 'Dettol' to sterilise the light.**

**Do not use any abrasive materials to clean the light.**

**CAUTION! The light is not waterproof, so do not use excessive cleaning fluid amounts.**

Suitably protect hands.

Wipe the light using clean tissue or soft towelling - pay special attention to the switch and handles.

Apply to all surfaces a 1% solution of sodium hypochlorite using a soft cloth.

Within 10 minutes, remove the chemical from all surfaces using a damp, soft cloth. The chemical will cause corrosion of metal parts, if it is not thoroughly removed.

Apply Isopropanol to the surfaces - this is an alcohol-based fluid which evaporates without leaving any residue and can be obtained as an impregnated-cloth applicator.

### 4.1 Troubleshooting

If the light does not illuminate, change the lamp-bar - see Section 5, below.

If the light still does not illuminate, further investigation should only be undertaken by a qualified electrician.

## 4.2 Routine maintenance

The Bilite is designed and manufactured to stringent quality standards. Observing the following procedures will help to maintain the light's optimum performance.

### Light-head

Operation	Suggested Interval	Method
Clean all exterior surfaces	As required	Disinfecting and cleaning directions - see section 4.

### Arm

Operation	Suggested Interval	Method
Lubricate wall-mount plate bush	Six Monthly	On wall-mounted units, lift the arm so its spigot is almost clear of the bush in the wall-mount plate and re-lubricate if required.
Lubricate ceiling mount spigot	Six Monthly	On ceiling mount units, support the arm and remove the 3 screws retaining the fitting adaptor into the down-tube. Lower the arm until the adaptor and key can be removed. Slide sleeve up and inspect for lubrication. Re-lubricate spigot and sleeve if required. Reassemble.
Check tightness of all five fixing screws.	One month after installation and then annually.	
Check balance of jib over whole range.		See section 6.

### Ceiling Mount

Operation	Suggested Interval	Method
Inspect 6 button head socket screws for tightness and check that washers are fitted under head.	Six Monthly	Tighten with appropriate hex key
Check that down-tube is rigidly mounted to the ceiling (do not exert undue force).	Annually	If any movement found - immediately advise your service dealer.

### Wall Mount

Operation	Suggested Interval	Method
Check security of wall fixing	Annually	Investigate any movement - ensure your building contractor is consulted if movement is found.

## 5. LAMP-BAR REPLACEMENT

In the event of lamp failure, switch off the unit, and remove the front fascia by easing the lugs at each end. The lamp-bar may then be withdrawn from the case.

**CAUTION:** the lamp will be very hot if the light has been recently used.

Being careful not to touch the bulb itself, fit a new lamp-bar by engaging its 2 prongs into the guide holes and pushing evenly home. Remember to order spare lamp-bars; LB1024.

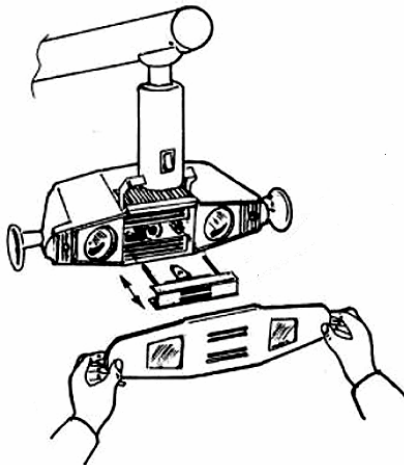
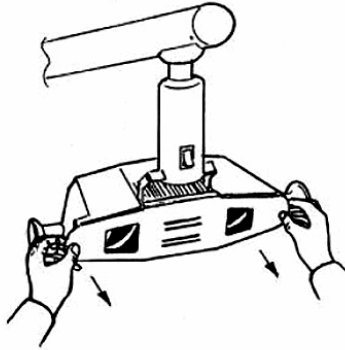

## 6. ADJUSTMENT OF ARM BALANCE TO ELIMINATE DRIFT

Insert a small implement (e.g. hexagonal key 2mm A/F) into the holes shown (Arrow A) and turn capstan in the direction of Arrow B until desired balance is obtained.

Note: To eliminate rise in the jib at its lowest position turn the capstan in the opposite direction to Arrow B.

To help make this adjustment, it may be necessary to remove the arm joint cover: Remove the 2 'snap-in' plugs and the 2 screws, allowing the cover half mouldings to be separated and the moving cover to slide down the jib arm. This provides better access to the slot through which the capstan nut is adjusted.

**Note: When re-assembling, ensure that the moving cover is correctly positioned with the 'T' notation on the component at the 'Top'.**

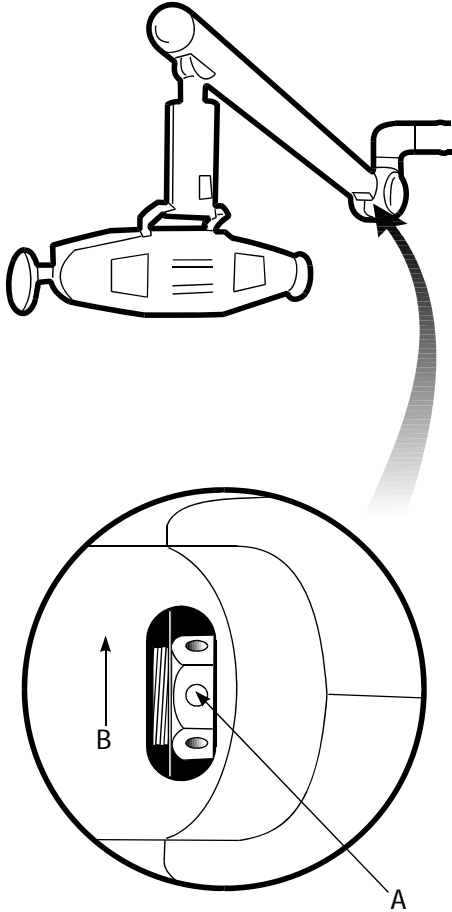

## 7. INSTALLATION

**CAUTION:** this product must be earthed.

### 7.1 Unit/chair mount with remote transformer

Mount the transformer in a suitable position under the chair.

Ensure that the transformer and electrical connections are sited so that they do not come into contact with liquid.

The transformer low voltage cable terminates in a Molex plug. The transformer is supplied with a low voltage cable which has suitable Molex adaptors at either end - one which will connect to the transformer only, the other to the Molex adaptor on the low voltage cable supply of the arm assembly.

Feed the low voltage cable through the support post and any umbilical to the transformer site. Make sure there are no sharp bends or possible contact with surfaces which may rub or cut the cable.

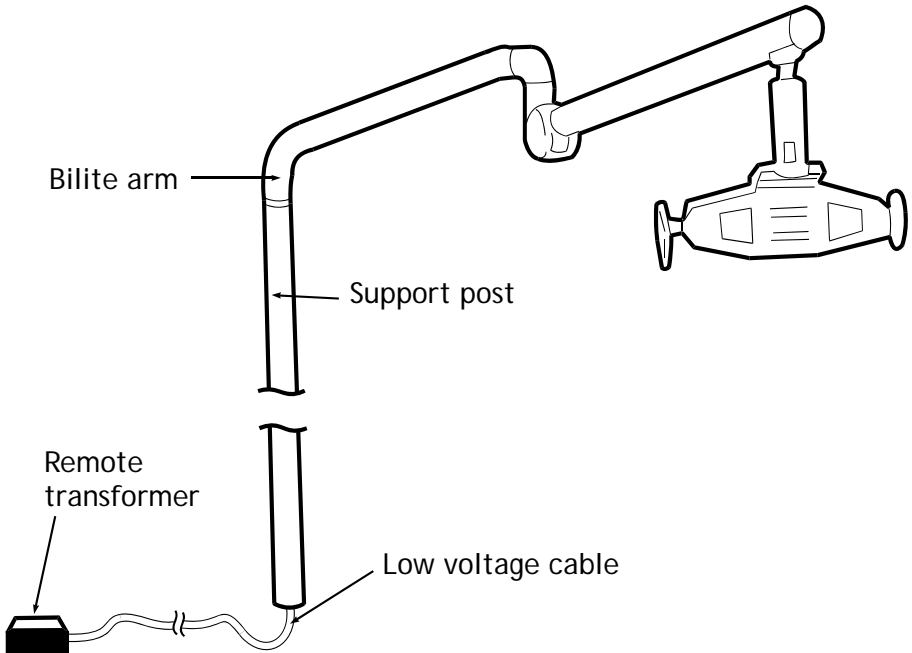

Ensure the post mount is truly vertical. Connect the low voltage cable to the arm assembly. Fit the arm to the post and connect the low voltage lead to the transformer.

Fit the light-head (see section 8)

## 7.2 Ceiling mount

Check you have the following items:

Ceiling-mount plate assembly
Large ceiling cover or small bezel trim (for false-ceiling installations)
Down-tube
Kit of fittings D10522
Adaptor D10523
Suspension arm
Light head
Power supply module

Determine where to mount the light; see the ceiling-load forces diagram below:

**WARNING: please note that this information is provided for guidance only and that a qualified builder or structural engineer should be consulted if you have any doubt about the suitability of the proposed mounting position.**

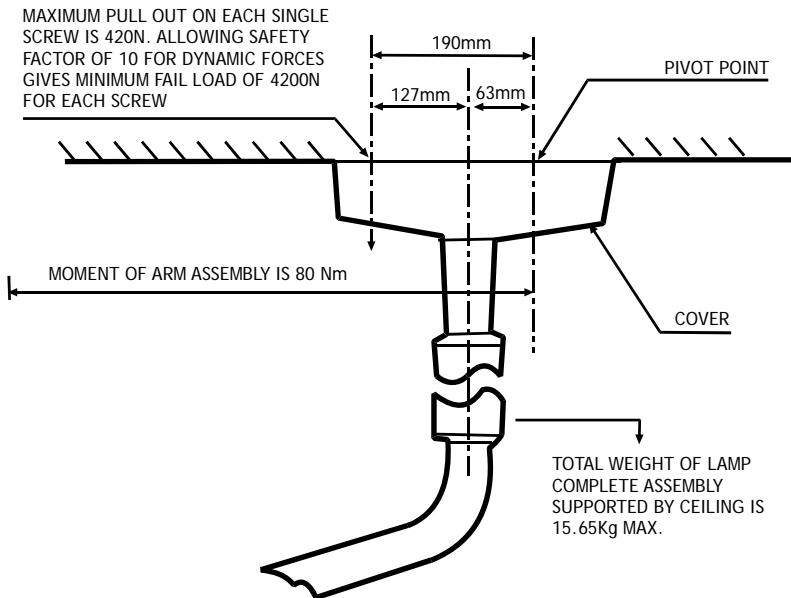

**WARNING: the light head operates from a low-voltage supply produced by a transformer in the ceiling mount assembly and fed through the suspension arm. On NO ACCOUNT should the arm be connected directly to the electrical mains.**

## Fitting the ceiling plate

Remove the clamp bolts, safety bolt/nylon insert nut and the clamp. Keep these parts in a safe place for use later.

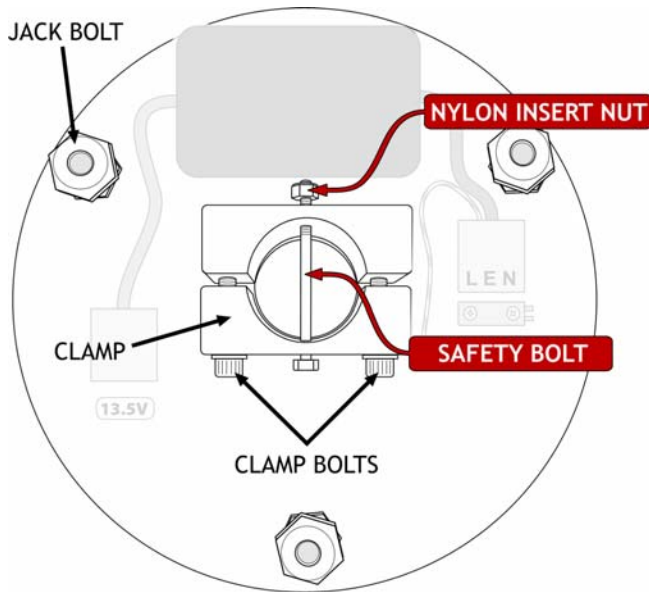

Fix the plate to the ceiling with bolts, screws or studs and nuts through the centre of each jack bolt. Do not fully tighten the fasteners at this point.

**Note:** The nuts thread-locked to the upper end of the 3 jack bolts act as pressure pads. These pressure pads must be seated firmly against the mounting surface.

The jack bolts can then be used to adjust the position of the ceiling plate and down-tube.

## Fitting the Down Tube

A 1 metre length of down-tube is included with all ceiling mount kits, and must be securely fitted in accordance with these instructions.

The down-tube must be cut to size on-site to suit the particular ceiling height.

Note when installed the down-tube must leave clearance above the ceiling mount plate to prevent the cable being trapped.

To accurately position the light, measure the distance between the ceiling mounting plate, and a point 2296 mm above the floor, this will be the correct trimmed down-tube length.

**Only shorten the down-tube from the end without 3 mounting holes.**

**De-burr as necessary.**

Loosely refit the clamp and clamp bolts. Fit the down-tube in the clamp and tighten the clamp bolts to firmly hold it in place. Drill a 6mm hole completely through the tube via the guide holes in the clamp and fit the safety bolt and nylon insert lock nut supplied.

**NOTE: TO ENSURE THE USER'S SAFETY, THE SAFETY BOLT AND NYLON INSERT LOCK NUT MUST BE FITTED PROPERLY**

Feed the end of the low-voltage cable assembly through the tube.

Tighten both clamp screws fully and evenly until the tube is firmly clamped.

Adjust the 3 large bolts such that the down-tube is absolutely vertical. Tighten the fixing bolts or screws to firmly clamp the jack bolts tight against the joist, tighten the thin locknuts and re-check that the down tube remains vertical, and the mounting plate has no movement. If necessary, repeat the adjustment.

Run the low-voltage cable to the mounted power-supply module, feed it through the grommet on the top of the module and connect it to the 2-way terminal block wired to the low-voltage output from the transformer.

Refit the module to its mounted rear plate.

If fitting where there is a suspended ceiling, cut a clearance hole in a ceiling tile, replace the tile and fit the trim.

If the ceiling mount is fitted to a conventional ceiling, fit the cover, holding it in place with the metal ring from the fitting kit.

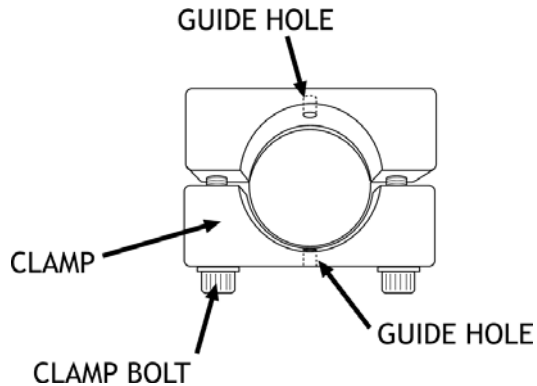

## Assemble the adaptor and primary arm

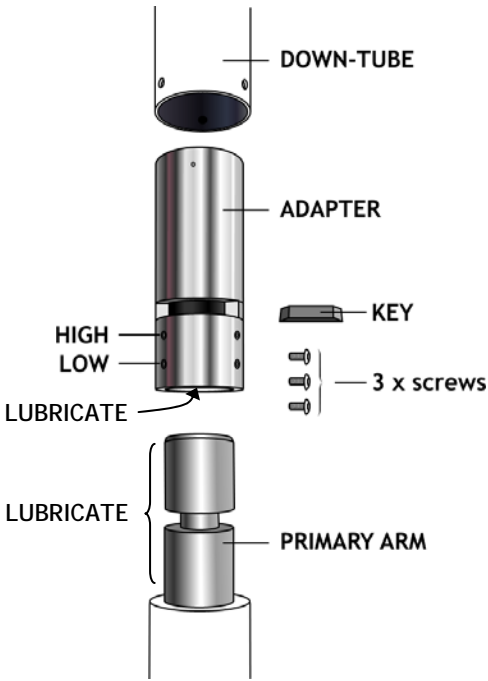

The short adaptor contains a rotation limit device to prevent cable damage whilst providing smooth movement and secure retention by the inclusion of a key.

Two rows of retaining screw holes (high and low) are provided.

To ensure the smooth rotation of the arm, it is essential that the spigot on the primary arm and the inside of the limited-rotation adaptor and retaining key be **lightly** lubricated before fitting together. A sachet of silicon grease is provided.

### **Note: This is a 2-person job!**

Join the low-voltage cable from the primary arm to that from the down tube. Keep the overall cable length as short as possible without making it too tight anywhere.

Slide the adaptor on to the primary-arm spigot with the 3 screw holes towards the arm, and fit the retaining key. Slide the adaptor into the end of the down-tube and retain it in place using the 3 screws and washers from the fitting kit.

Pull up any slack cable to ensure it doesn't get trapped.

Fit the jib-joint cover (see p.21).

Fit the light-head (see p.22).

Check everything for tightness and safety.

Check the arm and head for freedom of movement.

Rebalance the jib arm if necessary (see p.9).

# Wiring the ceiling mounted BILITE

The variable intensity control module should be mounted on a wall at a convenient position for the user.

Provide a suitable, earthed electrical supply to the variable intensity control module via a switched, fused spur.

Run a 1.5mm<sup>2</sup> twin and earth cable to the ceiling plate 230V terminal block.

Provide power to the power-supply module and switch on the green rocker switch which should illuminate.

Turn on the light with the rocker switch on its mounting swivel and check that the light illuminates and that the variable intensity control module works.

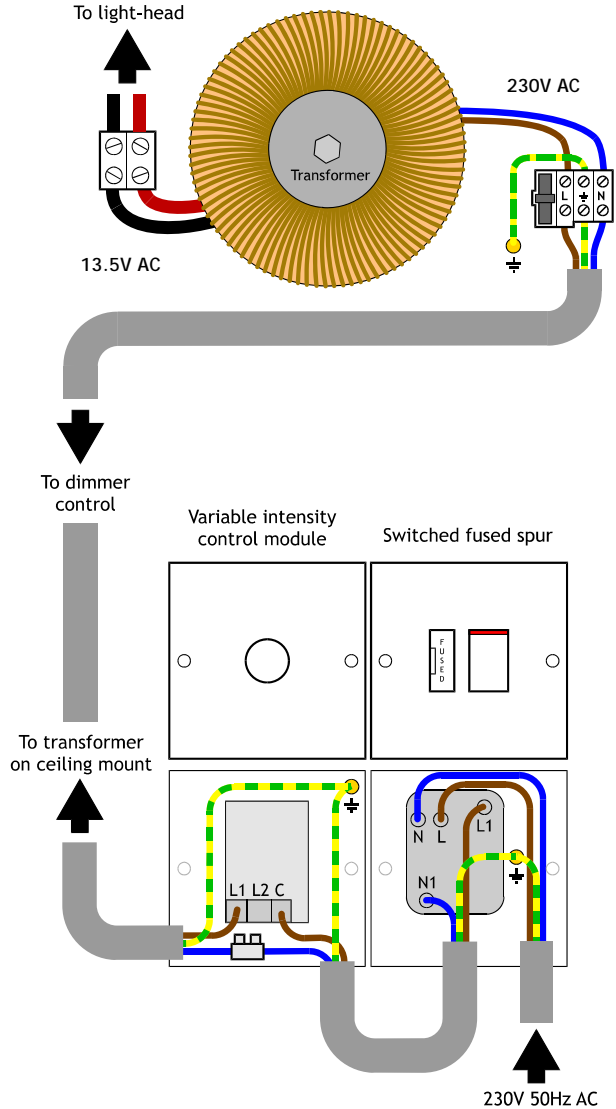

*Ceiling mounted Bilite wiring diagram*

## 7.3 Wall mount

Check you have the following items:

1. Wall-mount plate
2. Variable intensity power supply module
3. Light-head
4. Suspension arm

The arm assembly is packed and delivered with the spigot in the ceiling-mount configuration. For wall mounting, turn the primary arm through 180 degrees, as follows:

Place the arm on a non-scratch surface - remove the two screws as shown here.

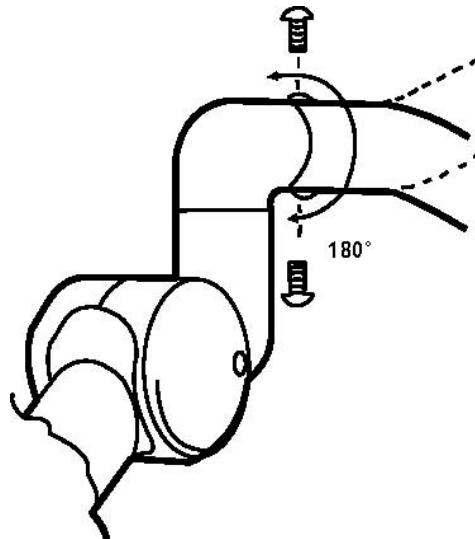

Turn the primary arm through 180° and refit the 2 screws tightly, making sure the cable is not trapped.

Mount the wall mount bracket. The top of the bracket into which the primary arm fits should be 1696 mm above the floor.

**WARNING! If in doubt, consult a building engineer.**

Secure the plate to the wall, ensuring that it is truly vertical.

**WARNING: the light-head operates from a low-voltage supply produced by a transformer in the power-supply module and fed through the suspension arm. On NO ACCOUNT should the arm be connected directly to mains electricity.**

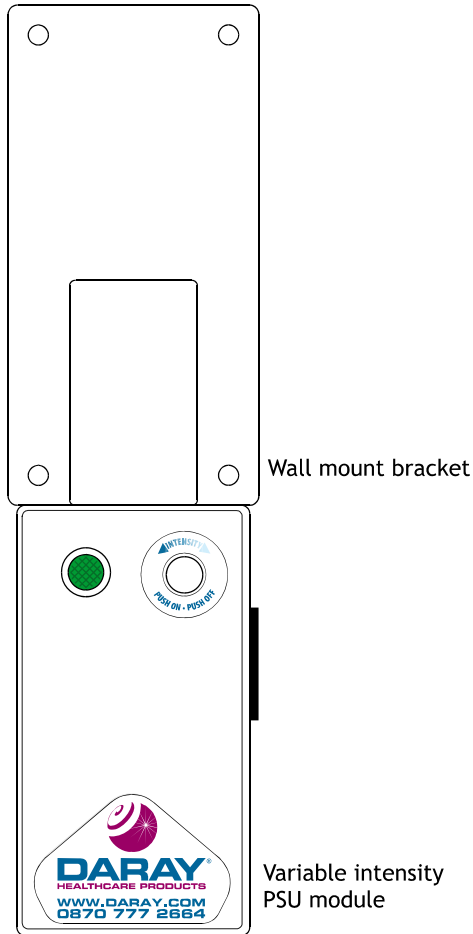

Fit the power-supply module directly under the wall mount bracket.

Remove the rear plate from the power-supply module by slackening the screw in each of the 4 corners.



To ensure the smooth rotation of the arm, **lightly** grease the spigot on the primary arm with the silicone grease provided. Slide the spigot into the bracket on the wall-mount plate, feeding the low-voltage cable from the primary arm through the top of the power-supply module.

Connect the low-voltage cable to the 2-way terminal block wired to the low-voltage output from the transformer.

The power-supply module requires an earthed mains electrical supply either fed into its rear or into a socket on the side depending on the module supplied.

Connect the incoming mains cable to the 3-way 'LEN' terminal block in the module.

Fasten the module's earth-bond wire to the rear-plate's earth stud.

Refit the module to its mounted rear plate.

Fit the jib-joint cover (see p.20).

Fit the light-head (see p.21).

Check everything for tightness and safety.

Check the arm and head for freedom of movement.

Rebalance the jib arm, if necessary.

Provide power to the power-supply module and check that the mains indicator illuminates.

Operate the variable intensity control module by pressing it. Rotate to dim. Check that the light-head illuminates and that the intensity control works.

## 8. FITTING THE LIGHT HEAD

**NOTE:** The arm will not balance until the head is fitted

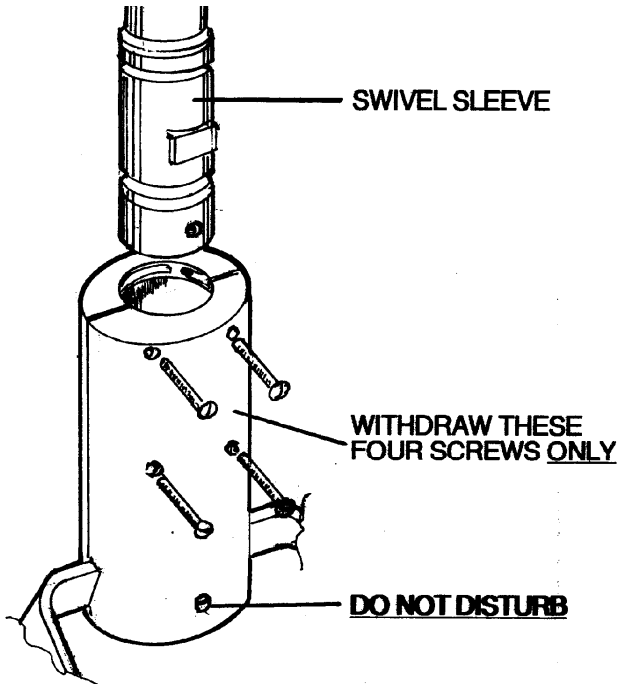

Remove four M3 screws, as shown, from the slip ring housing. Make sure the bottom fifth screw is left in place.

**Note:** the four M3 screws may be supplied separately in a plastic bag with the warranty card.

Ease the 2 halves of the slip ring housing open slightly and slide the lamp-head unit up over the swivel sleeve until the top face meets the lower face of the anchor block, ensuring that the flat on the swivel sleeve is positioned as shown.

Replace the four M3 screws so that they engage the slots in the swivel sleeve. Do not over-tighten the screws.

Check everything for tightness and safety.

Check the arm and head for freedom of movement.

Rebalance the jib arm, if necessary, as described above.

Provide power to the power-supply module and switch on the green rocker switch which should illuminate.

Turn on the light with the rocker switch on its mounting swivel. Check that the light illuminates and that the dimmer control works.

As necessary, realign the overlap of the 2 rectangular light patches by turning the adjusters on the rear of the light head using the tool provided.

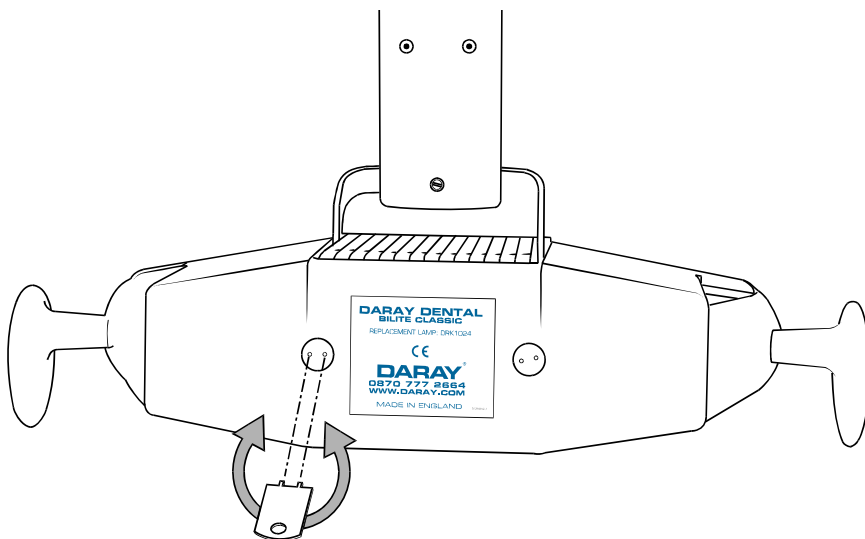

# Returns Policy

## IMPORTANT!

Before returning your item, you must call us on 0844 375 9000

We want you to be completely satisfied with your purchase. If you need to return goods purchased from DARAY Ltd, please read the following information carefully.

The DARAY Ltd returns policy provides guidance on when you can return goods we have supplied, and what you can expect from us once you do. To see our detailed returns policy and procedure visit [www.daray.co.uk/returns](http://www.daray.co.uk/returns)

TYPE OF RETURN	REMEDY
<b>DAMAGED GOODS OR DOA*</b> Goods which are physically damaged on delivery, or which do not function.	We must be notified within 24 hours of receipt.
<b>GOODS DEVELOPING A FAULT</b> Goods which have developed a fault within the warranty period.	Within 14 days of delivery we will replace the item as DOA*. If the fault develops after 14 days, but within the warranty period, we will initiate the returns procedure.
<b>NON WARRANTY</b> Goods which have developed a fault outside the warranty period.	If a fault develops outside the warranty period, we will initiate the returns procedure.
<b>OTHER</b> Any situation which is not covered by the above.	We will try to help, but we cannot normally offer a refund.

\*DOA - dead on arrival

For additional clarification, please refer to our terms and conditions at [www.daray.co.uk/terms](http://www.daray.co.uk/terms).

In a small number of cases, we may determine that a replacement would not work any better than the original product we supplied. In such cases we will only offer a refund rather than a replacement for qualifying returns.

Replacement bulbs are not eligible for returns, unless they are faulty or damaged.

Spare parts ordered on our website or from supplied part codes are not be eligible for credit. We will accept returns and exchange for the correct item.

If you purchase an item incorrectly you can return it within 14 days and it can be exchanged for another product of equal or higher value, excluding transportation charges incurred.

If you send us goods that do not qualify for return, you will invalidate your claim to any refund, and you will be obliged to compensate DARAY Ltd for the cost of return postage and any other reasonable costs incurred processing the goods.

Your statutory rights are not affected

# WARRANTY

## TERMS AND CONDITIONS OF WARRANTY

1. To qualify for this warranty you must register on [www.daray.co.uk](http://www.daray.co.uk) or return to DARAY Ltd (DARAY) the duly completed warranty-registration form accompanying the product.
2. DARAY warrants this product (excluding lamp) against faulty material and workmanship during the period of the warranty. The period of warranty is the period stated on your warranty card and commences on the date of purchase of the product. In the event that the product is not in good working order DARAY will provide, during the warranty period, a free repair service within the United Kingdom. The warranty is subject to proof of purchase being provided; therefore, you should retain your original receipt.
  - 2.1 The repair service consists of the provision of spare parts and/or replacement products (at DARAY's discretion) which will be provided on an exchange basis and will either be new, equivalent to new or reconditioned. All replaced spare parts and products shall become the property of DARAY.
  - 2.2 DARAY's only obligation under this warranty is the provision of the service as set out above.
  - 2.3 All products are returned to DARAY at the customer's cost and risk. Products to be returned should be adequately packed. For the address to send returns to please visit [www.daray.co.uk](http://www.daray.co.uk)
3. DARAY's arrangements for providing service provided under this warranty may include the use of sub-contractors.
4. This warranty does not cover damage or defects in the Product caused by or resulting from:
  - Wilful neglect or negligence by anyone other than DARAY;
  - Improper use, storage or handling of the product;
  - Use of non-DARAY approved parts (such as replacement lamps) not compatible with the Product;
  - Fire, accident or disaster;
  - Use of non-DARAY modifications other than in accordance with DARAY's instructions;Attachment of fittings and accessories not approved by DARAY;  
Repairs, modifications carried out by service personnel not approved by DARAY;
  - Damage caused by chemical corrosion from cleaning agents not approved by DARAY.
  - Failure to use or install the product in accordance with the manufacturer's instructions.
5. Nothing in this warranty shall have the effect of restricting or excluding the liability of DARAY in respect of:
  - a) Death and personal injury caused by the negligence of DARAY, or for fraud;
  - b) Under the *Consumer Protection Act 1987* to a person who has suffered damage caused by a defective product or to a dependant or relative of such a person;
  - c) Direct damage to your property caused by the proven negligence of DARAY.
6. This agreement does not give any rights other than those expressly set out above and in particular, DARAY will not be responsible for any loss of income, profits or contracts or any direct or indirect consequential loss, damage caused to or suffered by the purchaser as a direct result of this agreement.
7. This warranty is offered (subject to these terms and conditions) in addition to, and does not affect your statutory rights.
8. DARAY may disclose your details and other personal information to companies within the DARAY group including any subsidiary company or sub contractor of DARAY for the purposes of performing our obligations hereunder.
9. You must not resell outside the UK any products supplied by DARAY and covered by the *Export of Goods (Control) Order 1992* (or any law that replaces it) without obtaining all necessary licences. You also agree not to sell the product in the UK if you know or think that the person buying the product intends to export it without getting the necessary licences. You agree to impose similar conditions to these on anyone you sell the product to.
10. These conditions shall in all respect be governed and construed in accordance with English law and the exclusive jurisdiction of the English courts.



# DARAY<sup>®</sup> HEALTHCARE PRODUCTS

WARRANTY REGISTRATION  
TO VALIDATE YOUR WARRANTY  
PLEASE COMPLETE IN BLOCK CAPITALS  
AND RETURN IN A WINDOWED DL ENVELOPE  
TO OUR FREEPOST ADDRESS

**ALTERNATIVELY REGISTER ONLINE AT [WWW.DARAY.COM](http://WWW.DARAY.COM)**



## 3 YEAR AFTERCARE PLAN

NAME:	
COMPANY:	
EMAIL:	
PHONE:	
FAX:	

ADDRESS:

--

PURCHASED FROM:

--

DATE OF PURCHASE:

--

Freepost Plus RRAS-YGXE-SLBC  
Daray Ltd  
Marquis Drive  
SWADLINCOTE  
DE12 6EJ

Occasionally DARAY would like to send you information about our special offers and promotions. If you do not wish to receive such information, please tick here:

Privacy statement: DARAY will not pass on your details to any third party.

PRODUCT:
SERIAL No:





**DARAY**<sup>®</sup>  
HEALTHCARE PRODUCTS

**ILLUMIN**<sup>™</sup>

**MEDISYS**<sup>®</sup>

**I****MAGNIFY**<sup>®</sup>

**VitalSignZ**<sup>™</sup>

**LifeSignZ**<sup>™</sup>

**BioSignZ**<sup>™</sup>

**NfuZe**<sup>™</sup>

**VetZ**<sup>™</sup>



Marquis Drive · Moira · Derbyshire · DE12 6EJ  
Tel: 0844 375 9000 · Fax: 0333 321 0973  
email: [info@daray.co.uk](mailto:info@daray.co.uk) · url: [www.daray.co.uk](http://www.daray.co.uk)